

Grutas de la Baffena Village

















Grutas de la Ballena Village



Desarrollos inmobiliarios





Grutas de la Ballena Village

**La
to
rre**

Desarrollos
inmobiliarios

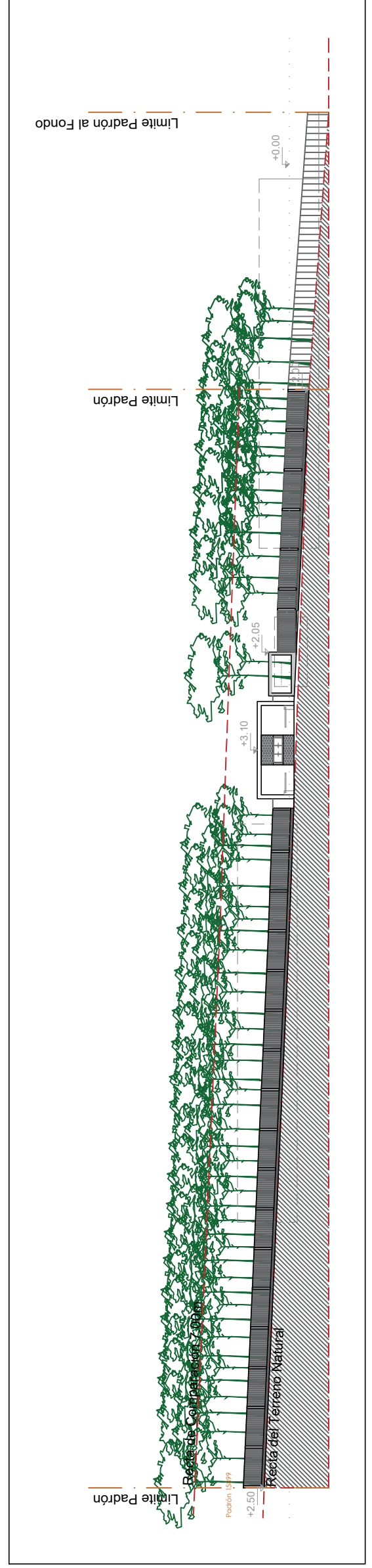
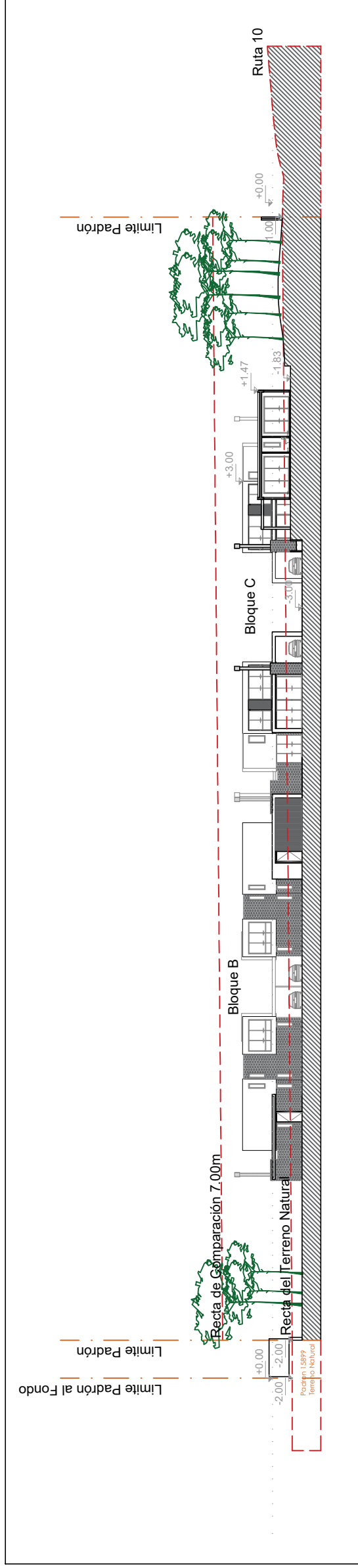
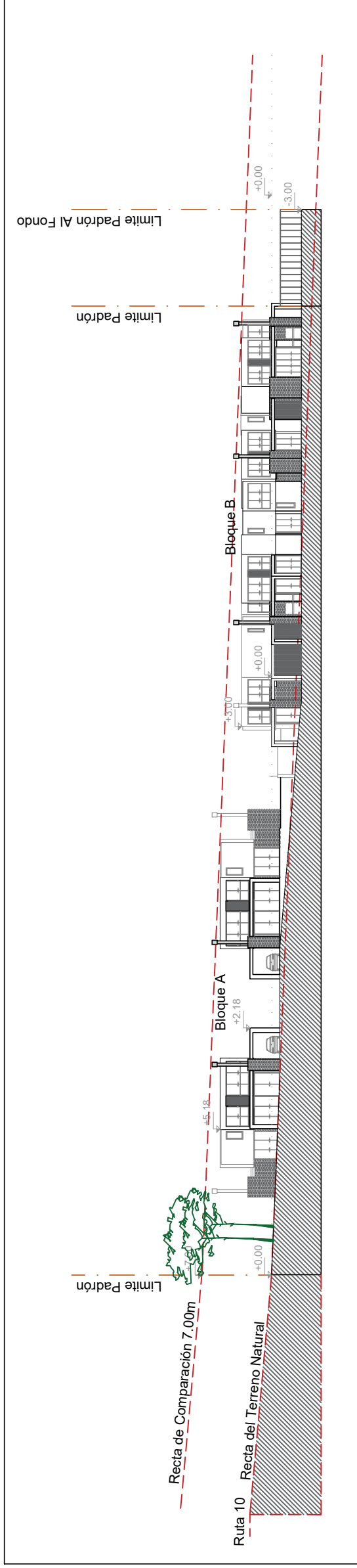

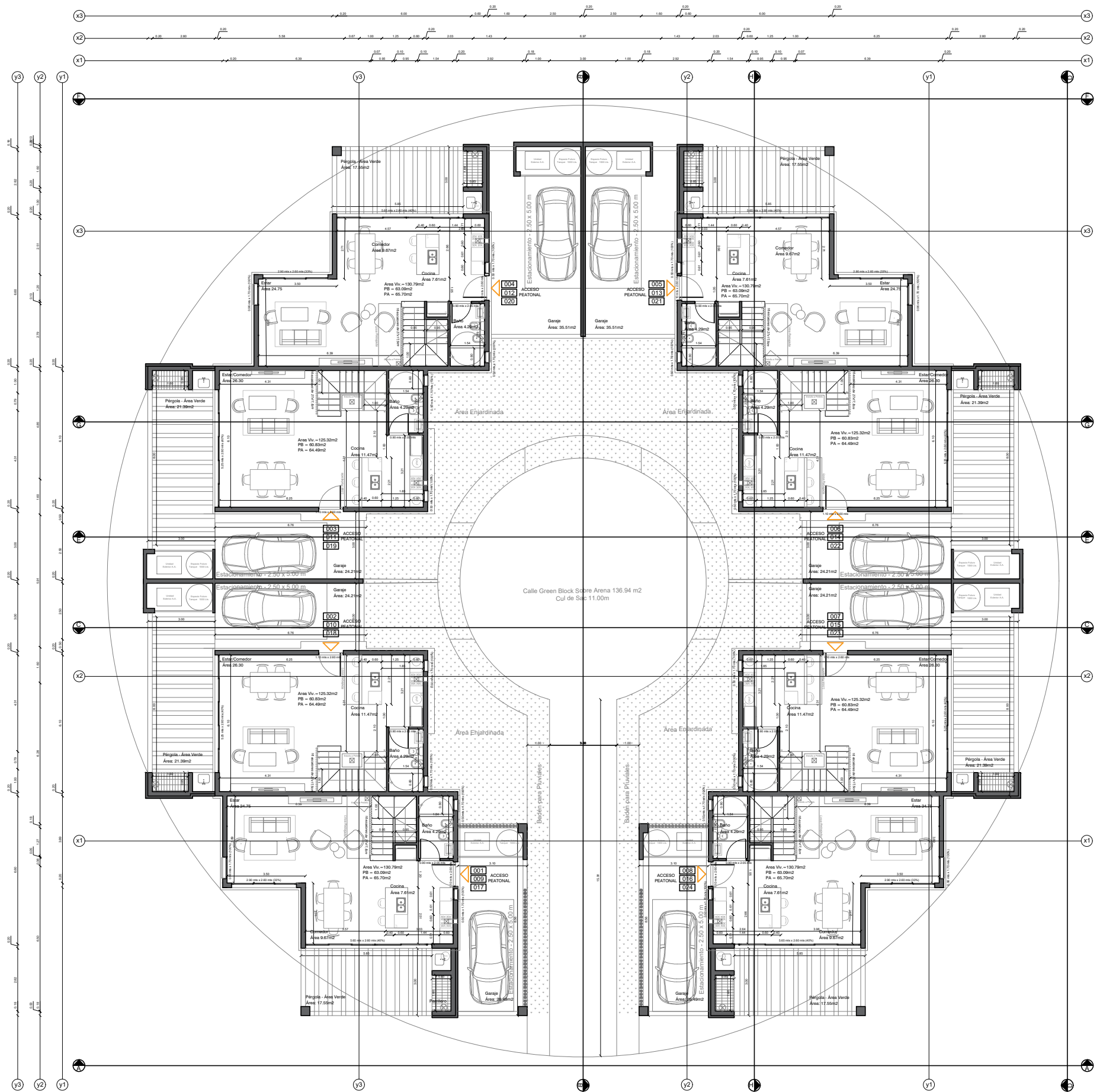



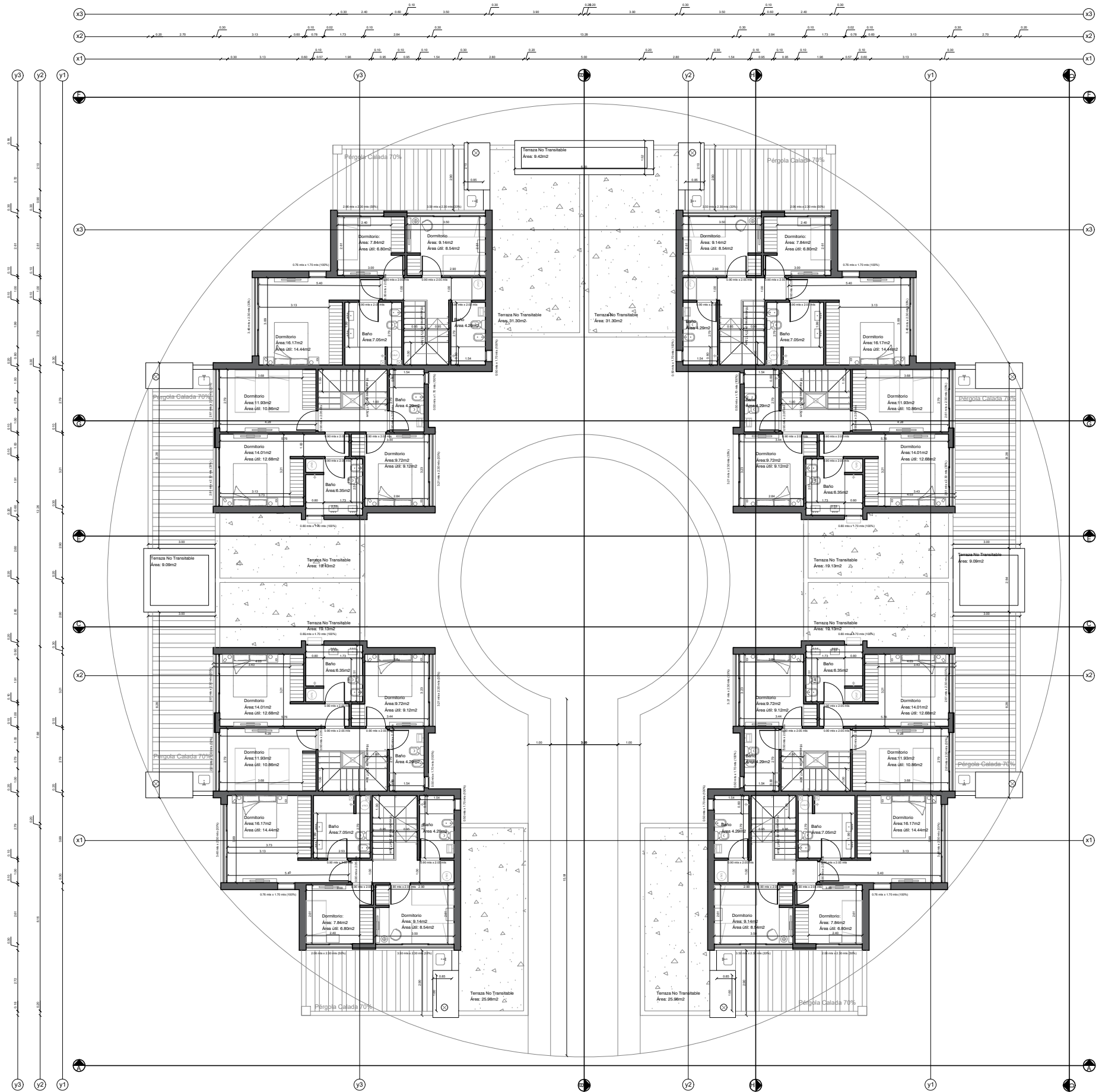

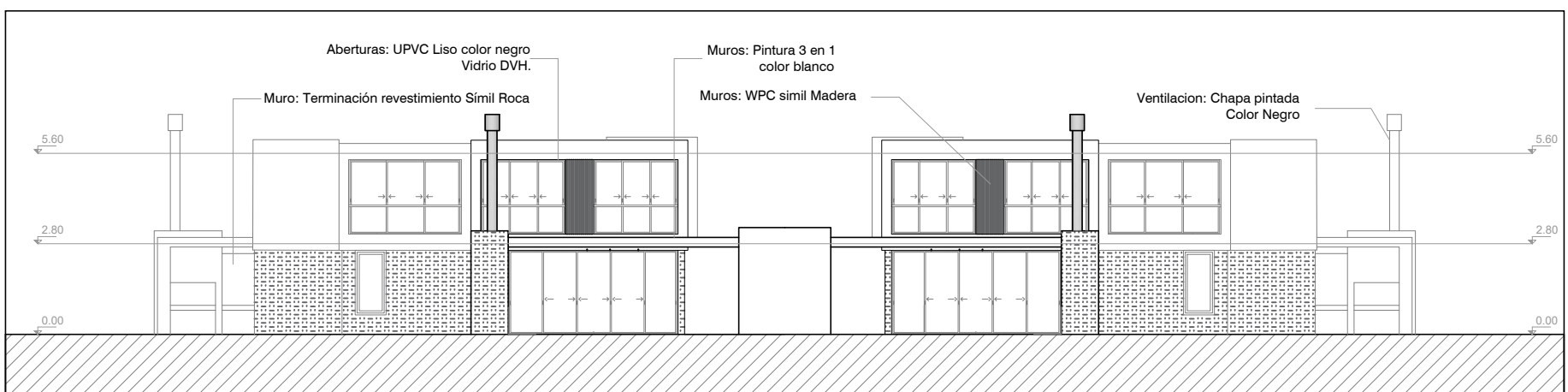
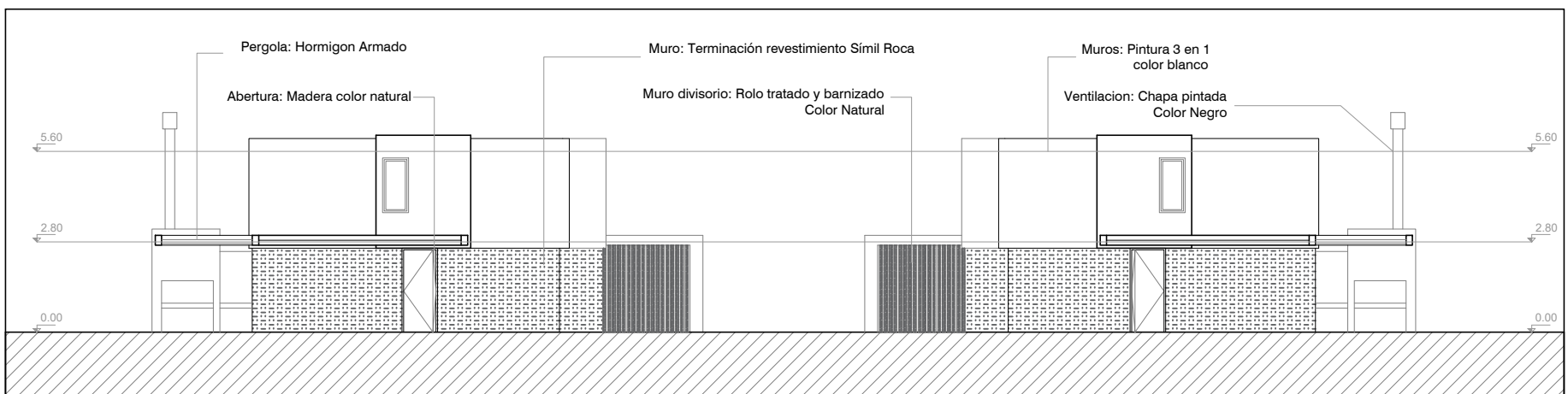
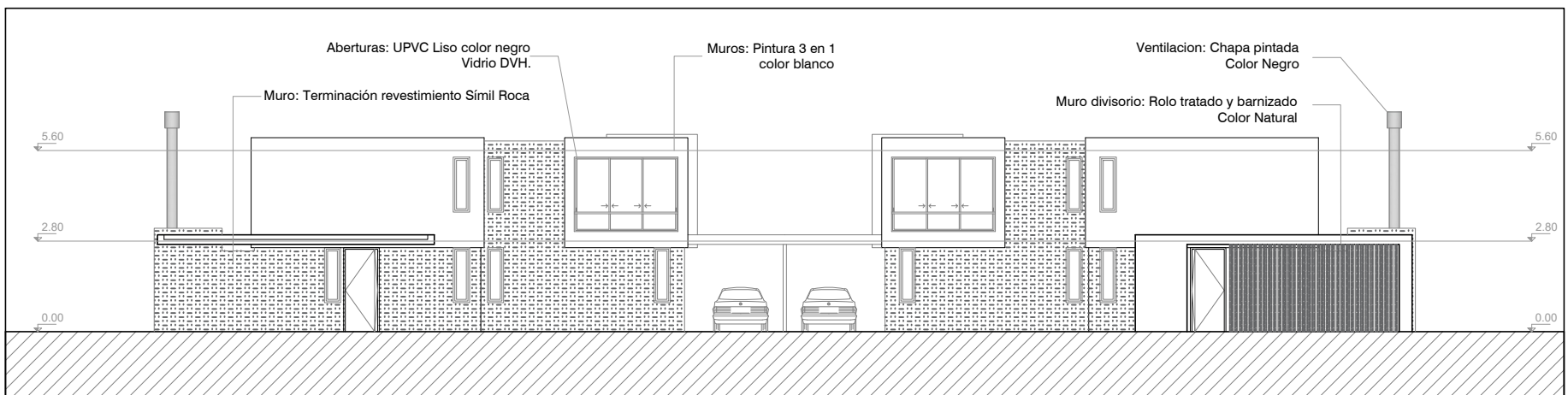
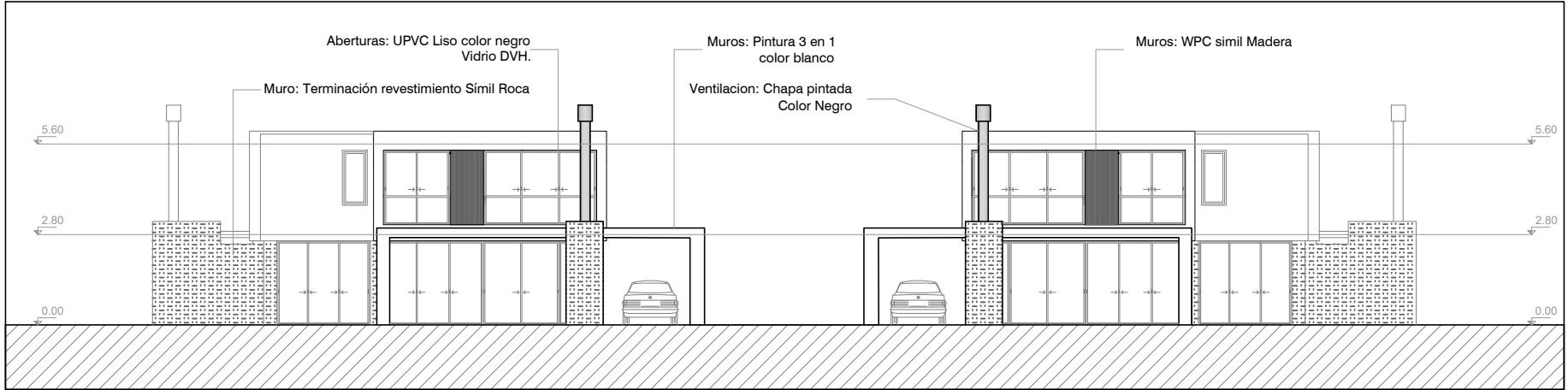

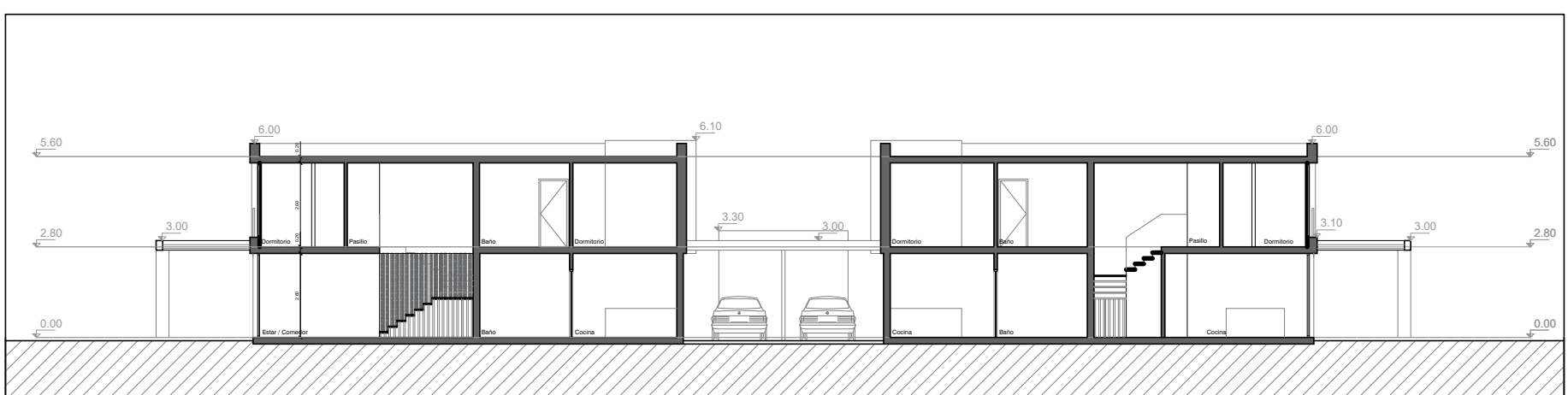
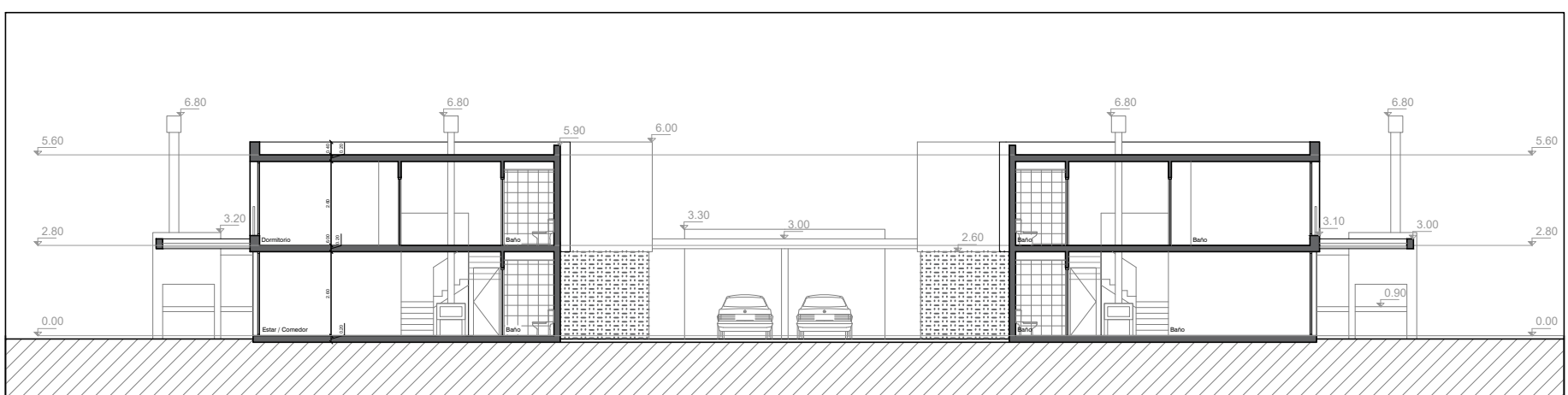
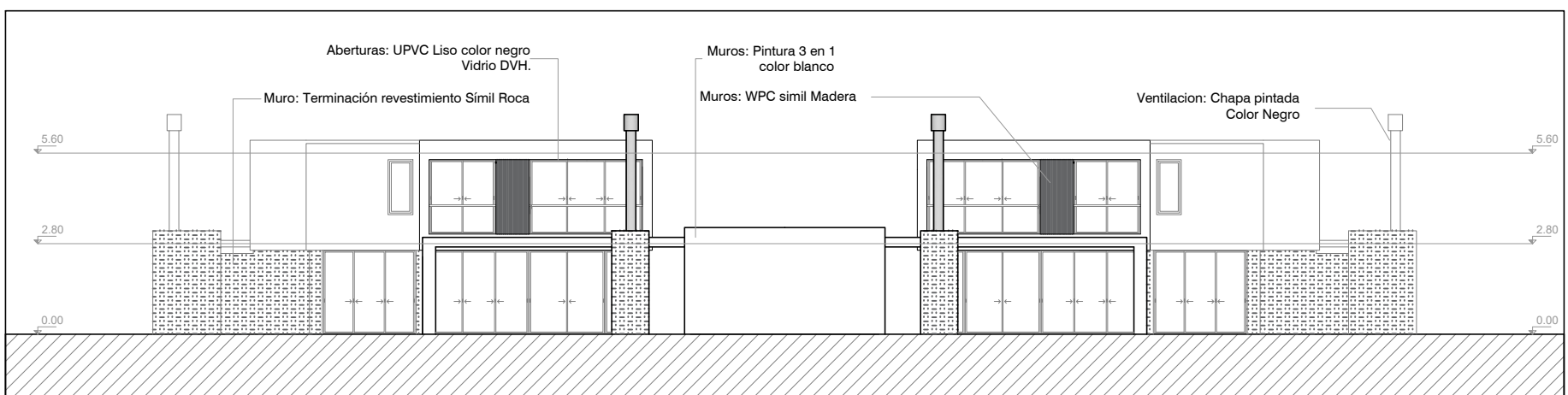
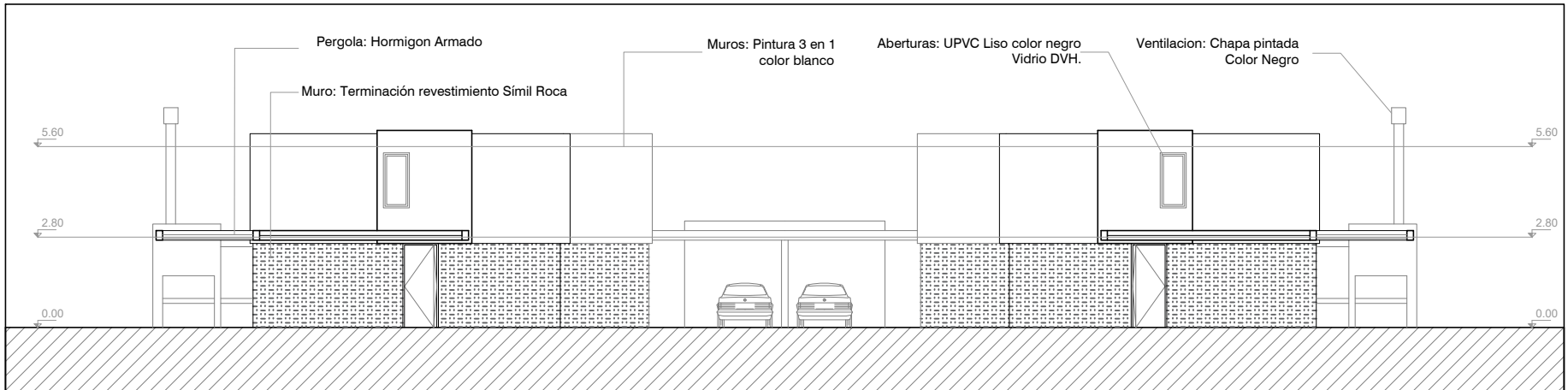

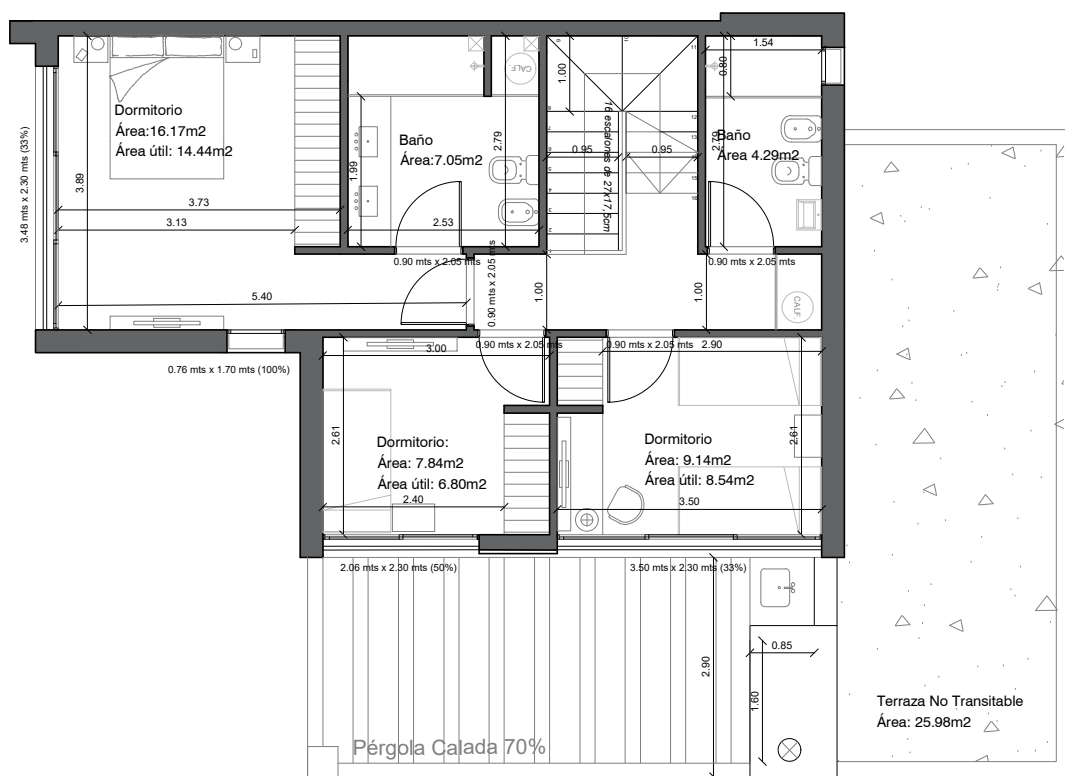
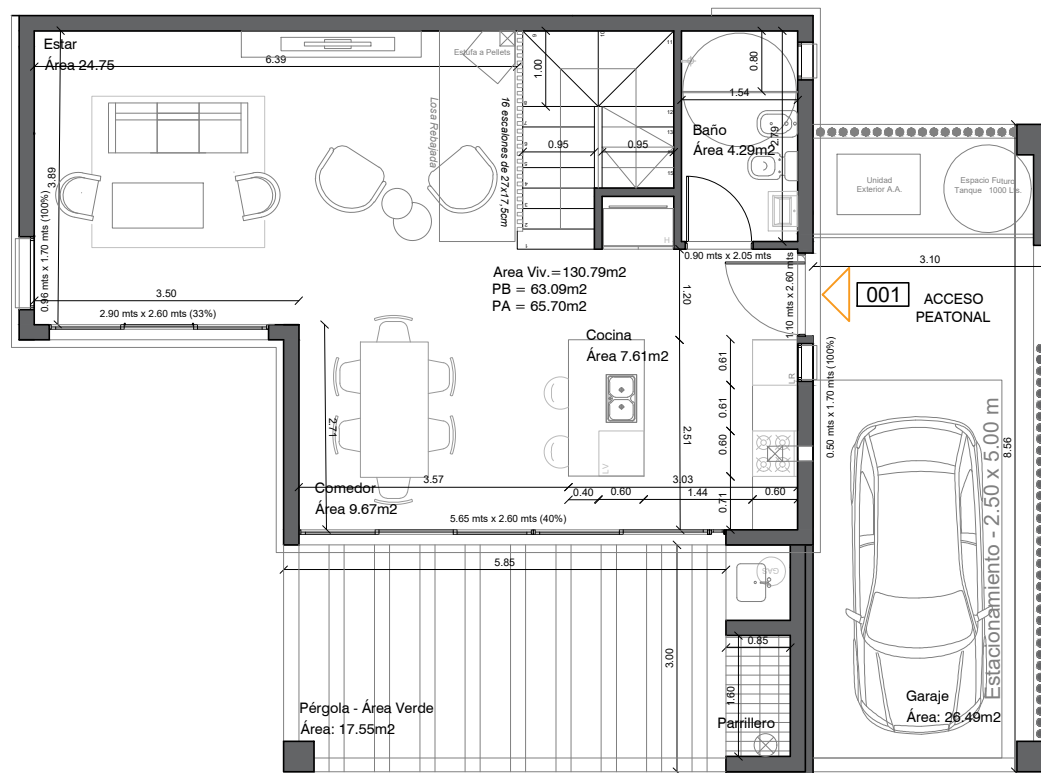

Apartamento 001 - Bloque A

130.79 m²

ÁREA TOTAL	700.80 m ²
ÁREA VIVIENDA	130.79 m ²
ÁREA DE USO EXCLUSIVO (sin viv.)	570.01 m ²

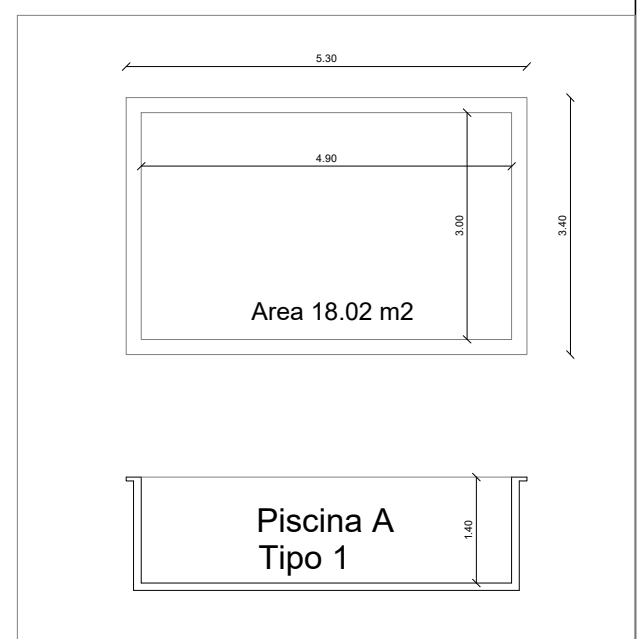

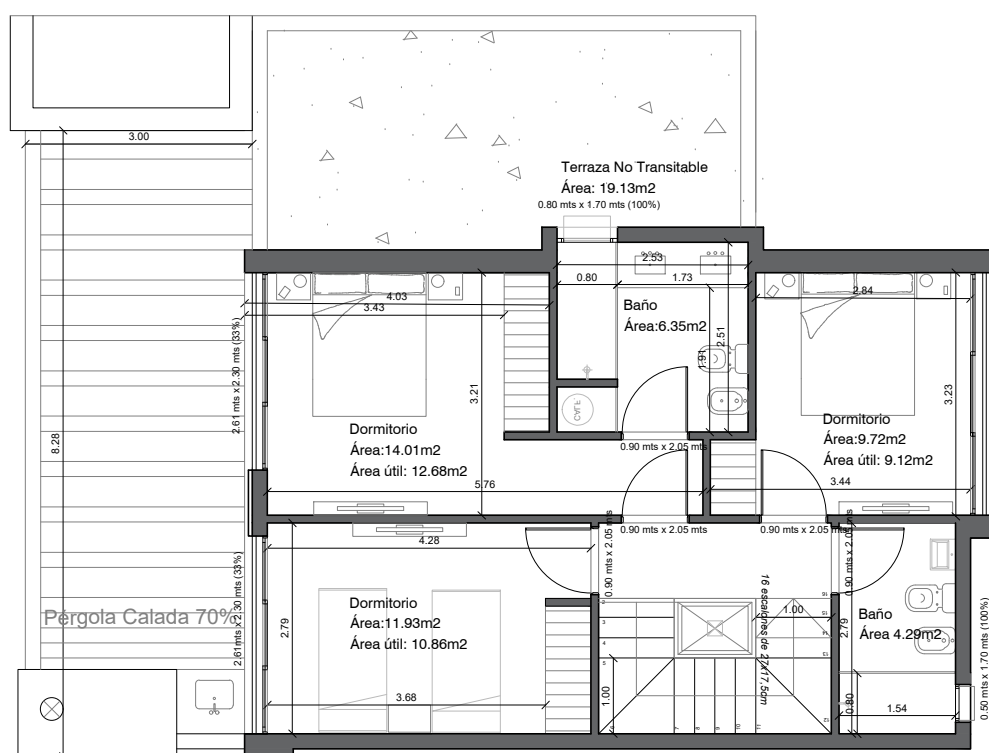
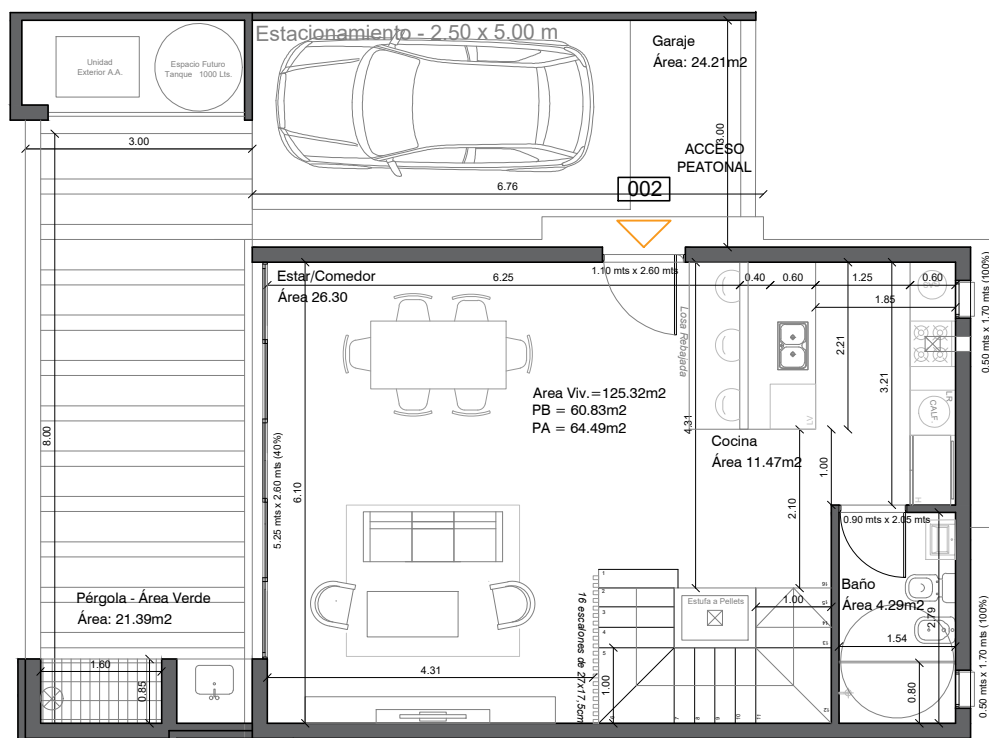

Apartamento 002 - Bloque A

125.32 m²

ÁREA TOTAL	362.95 m ²
ÁREA VIVIENDA	125.32 m ²
ÁREA DE USO EXCLUSIVO (sin viv.)	237.63 m ²

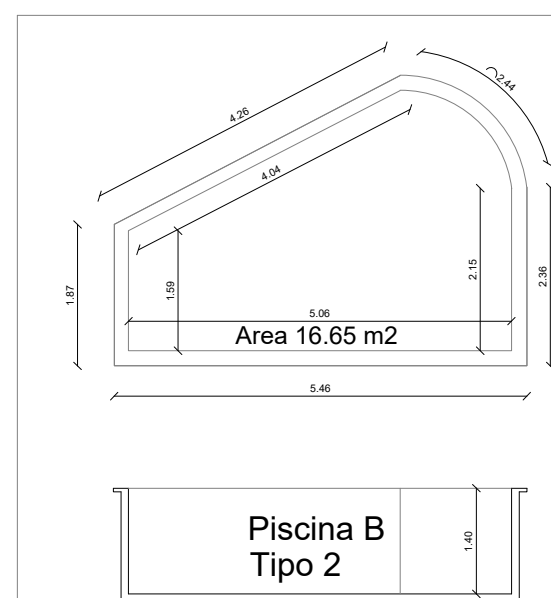

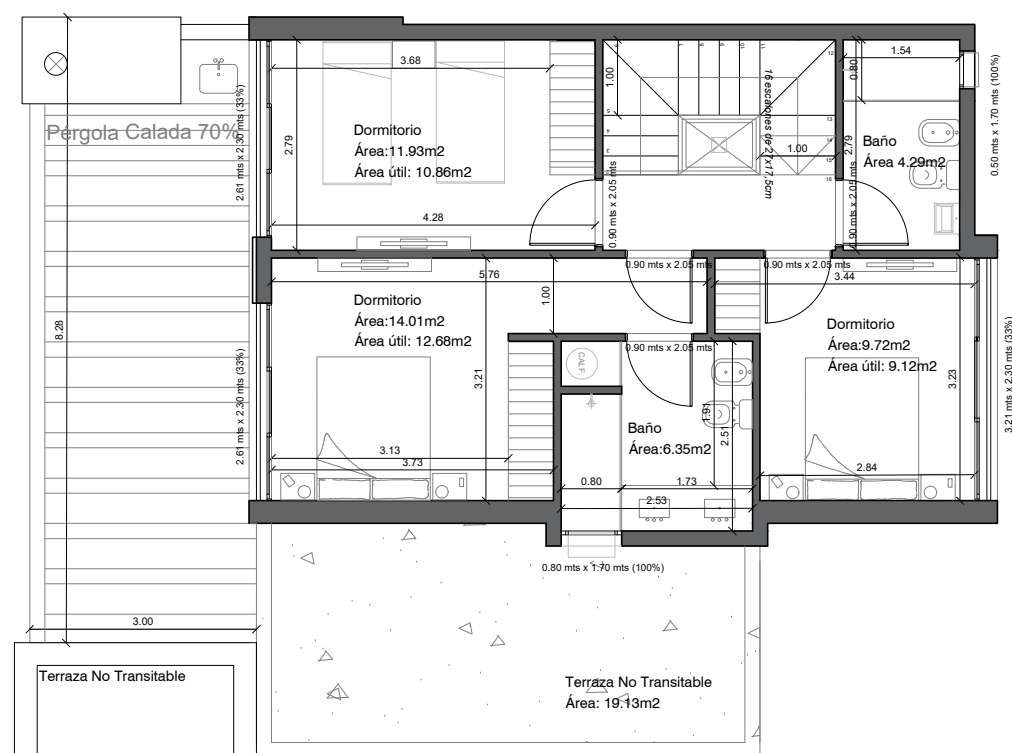
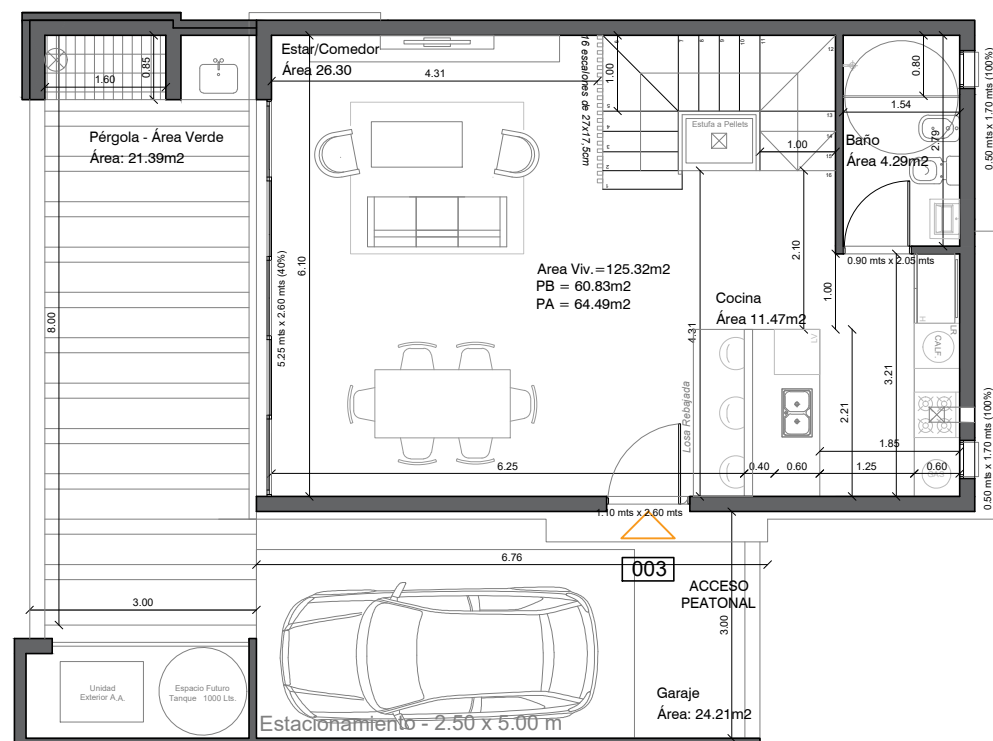

Apartamento 003 - Bloque A

125.32 m²

ÁREA TOTAL	405.69 m ²
ÁREA VIVIENDA	125.32 m ²
ÁREA DE USO EXCLUSIVO (sin viv.)	280.37 m ²

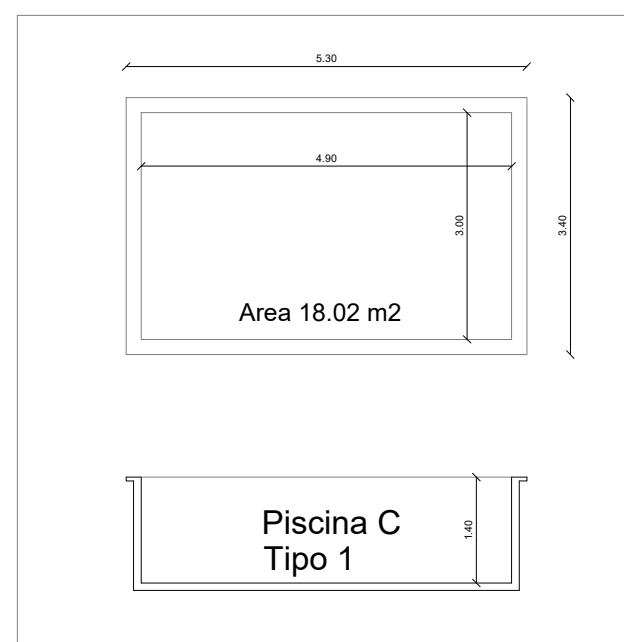

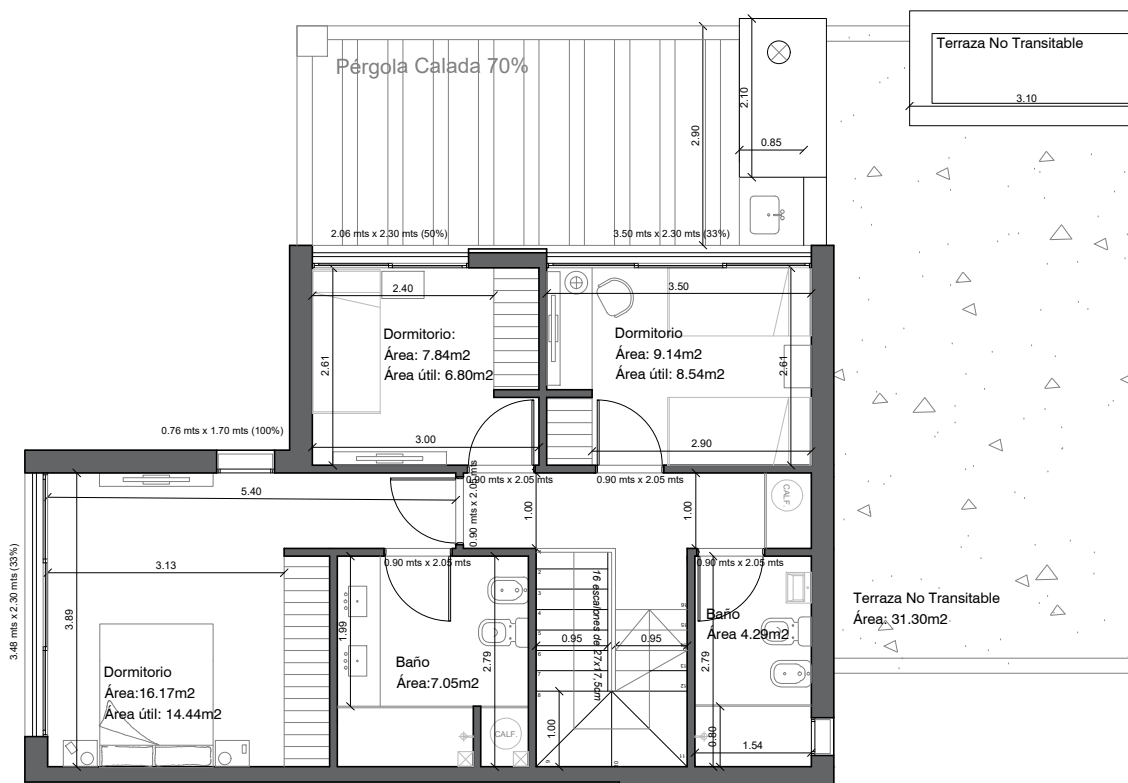
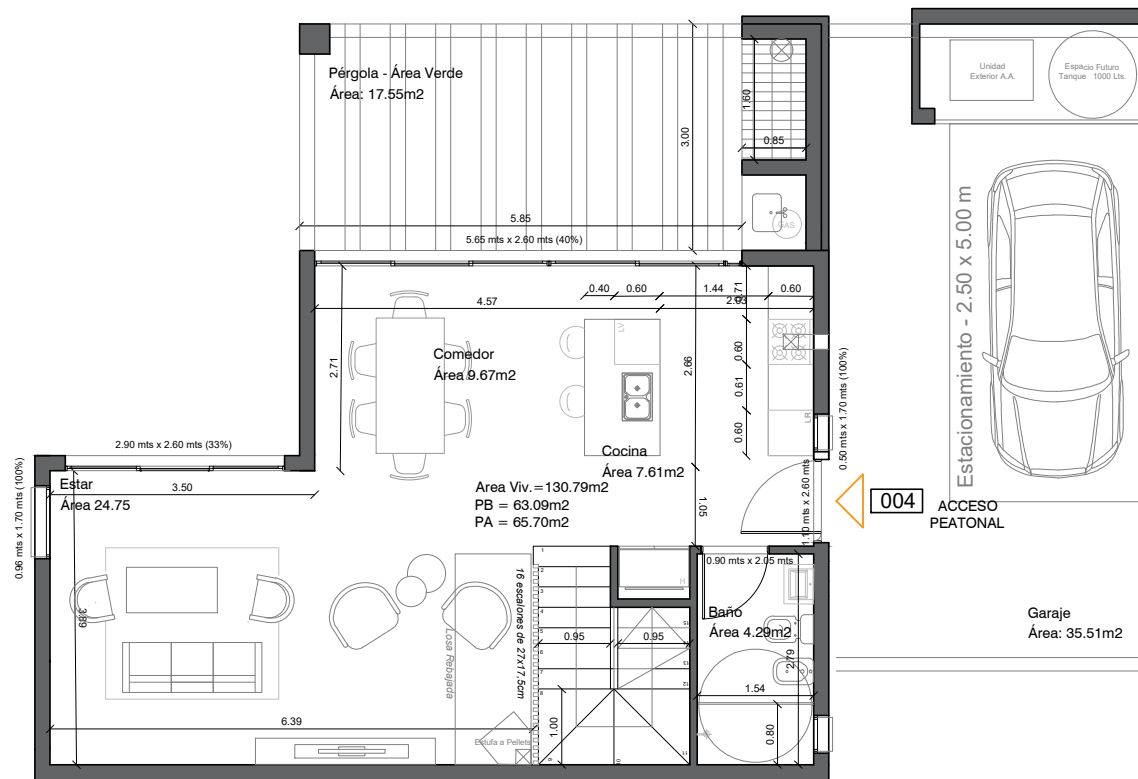

Apartamento 004 - Bloque A

130.79 m²

ÁREA TOTAL	730.39 m ² *
ÁREA VIVIENDA	130.79 m ²
ÁREA DE USO EXCLUSIVO (sin viv.)	599.60 m ² *

* 75,80 m² pertenecen a la Sub Estacion

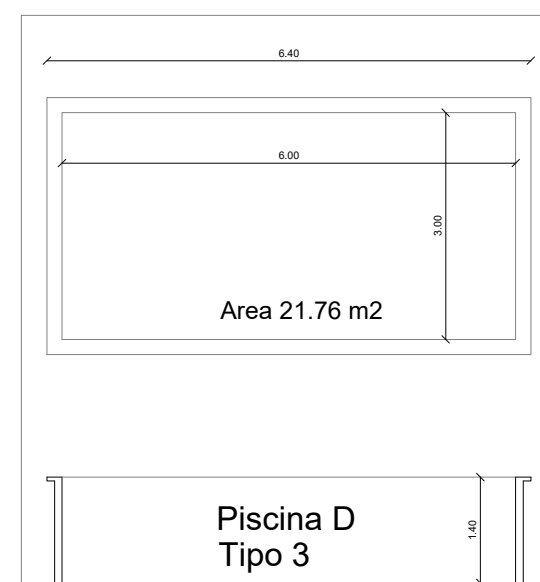

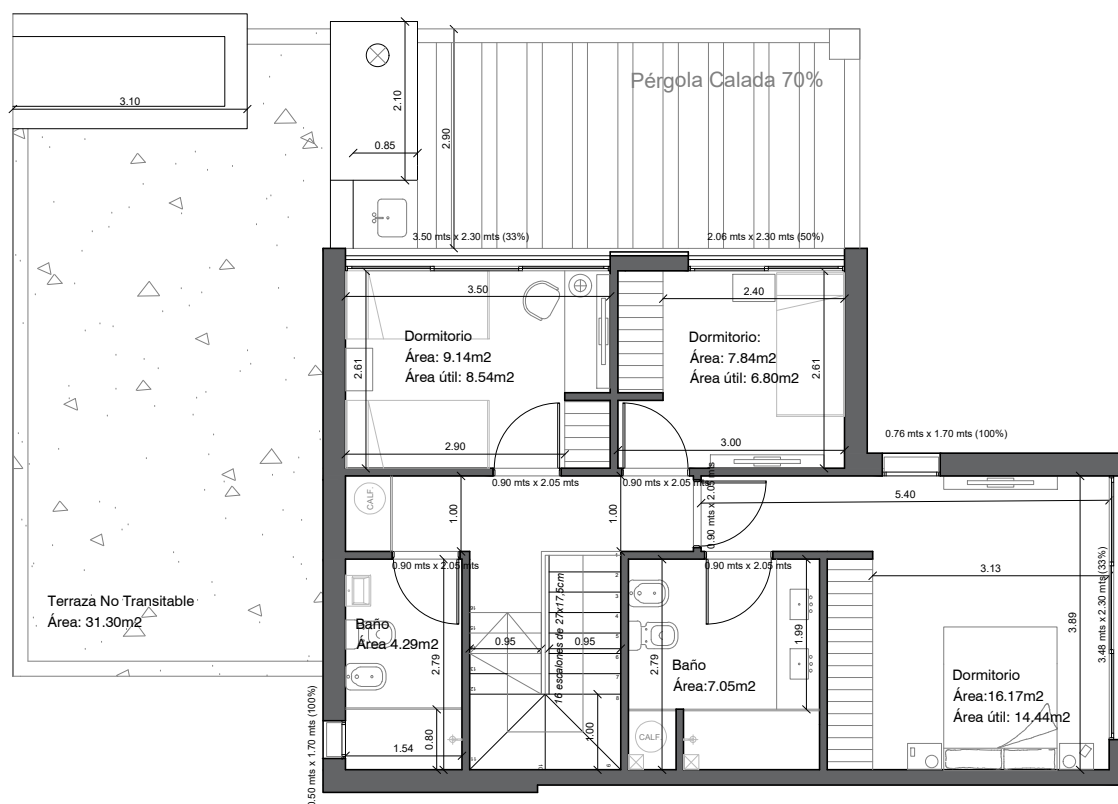

Apartamento 005 - Bloque A

130.79 m²

ÁREA TOTAL	384.85 m ²
ÁREA VIVIENDA	130.79 m ²
ÁREA DE USO EXCLUSIVO (sin viv.)	254.06 m ²

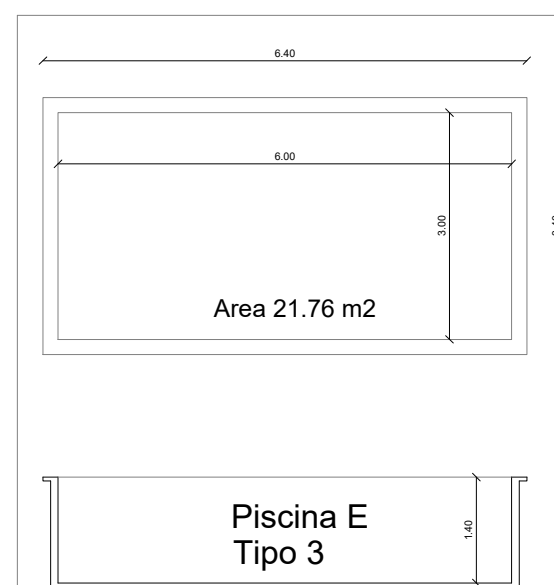

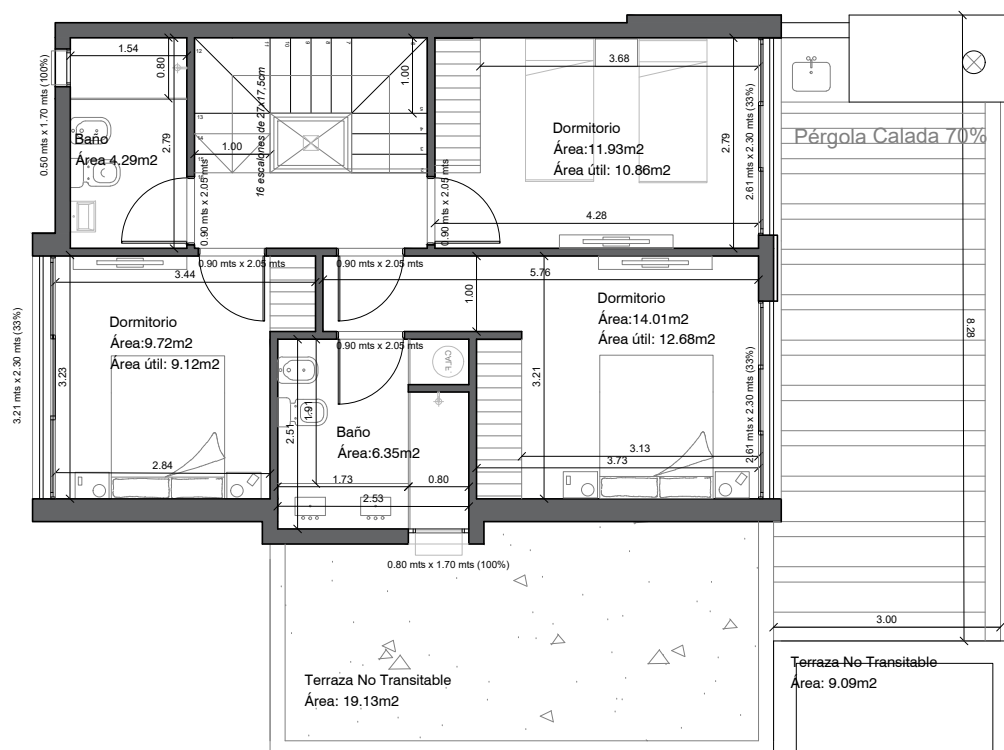
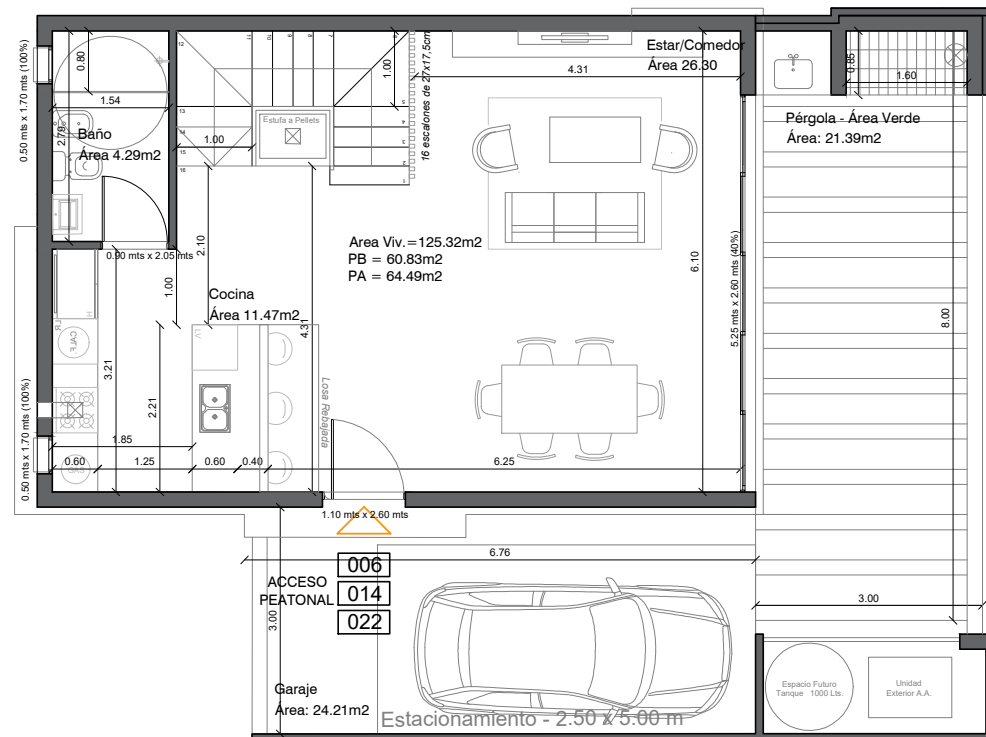

Apartamento 006 - Bloque A

125.32 m²

ÁREA TOTAL	242.18 m ²
ÁREA VIVIENDA	125.32 m ²
ÁREA DE USO EXCLUSIVO (sin viv.)	116.86 m ²

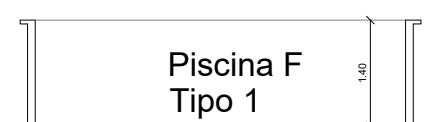
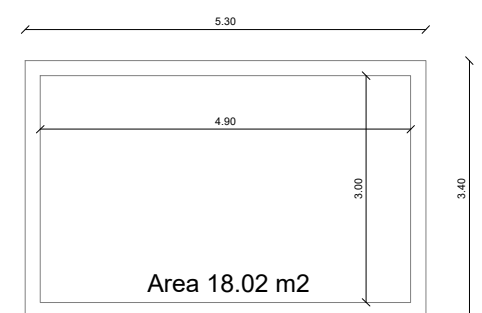

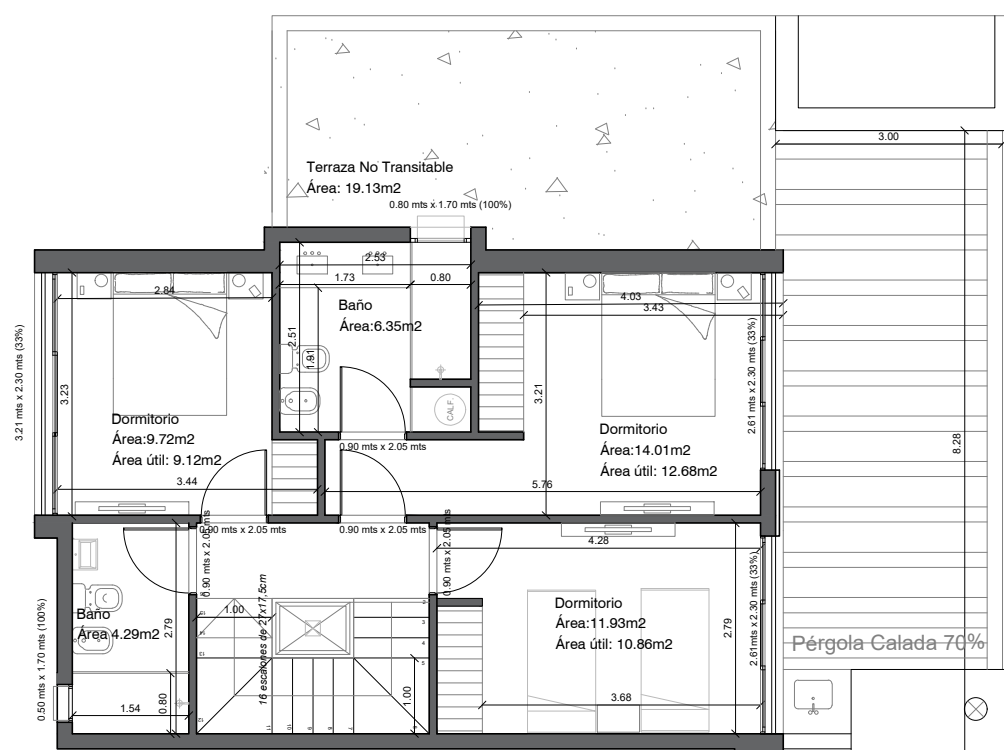
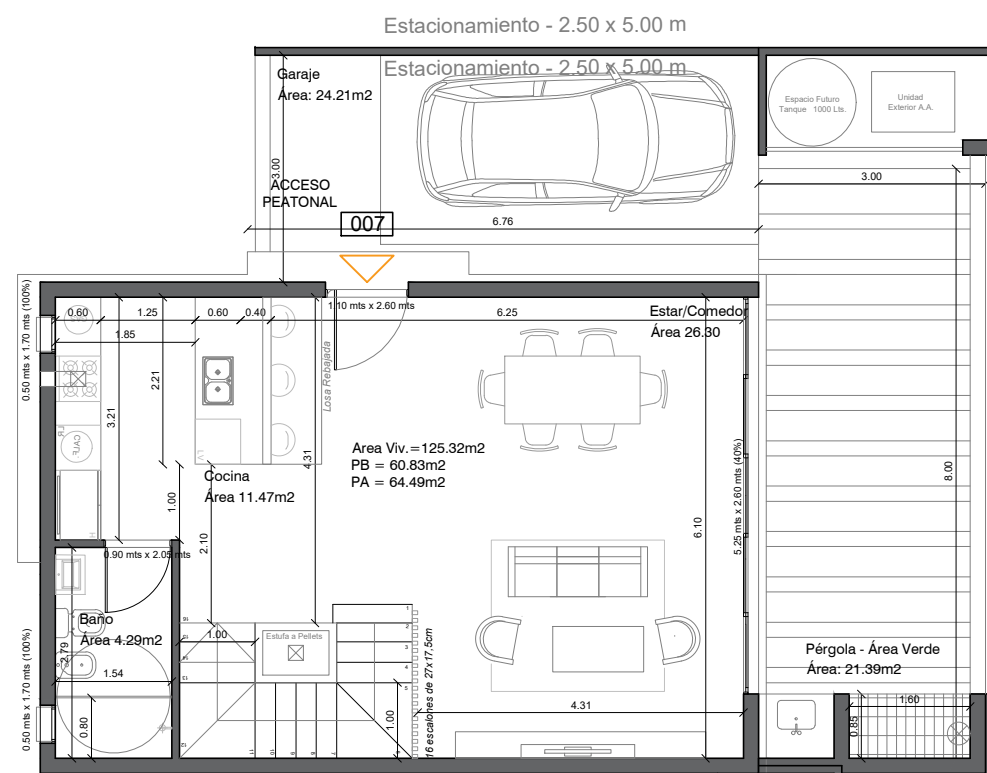

Apartamento 007 - Bloque A

125.32 m²

ÁREA TOTAL	219.66 m ²
ÁREA VIVIENDA	125.32 m ²
ÁREA DE USO EXCLUSIVO (sin viv.)	94.34 m ²

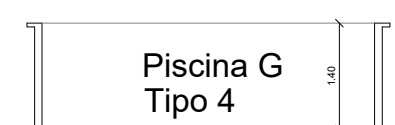
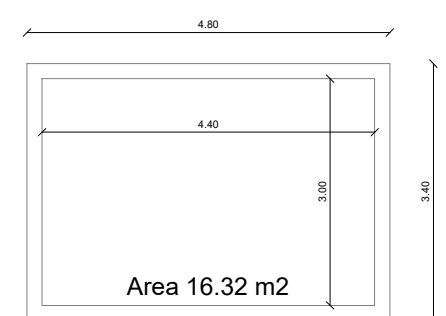

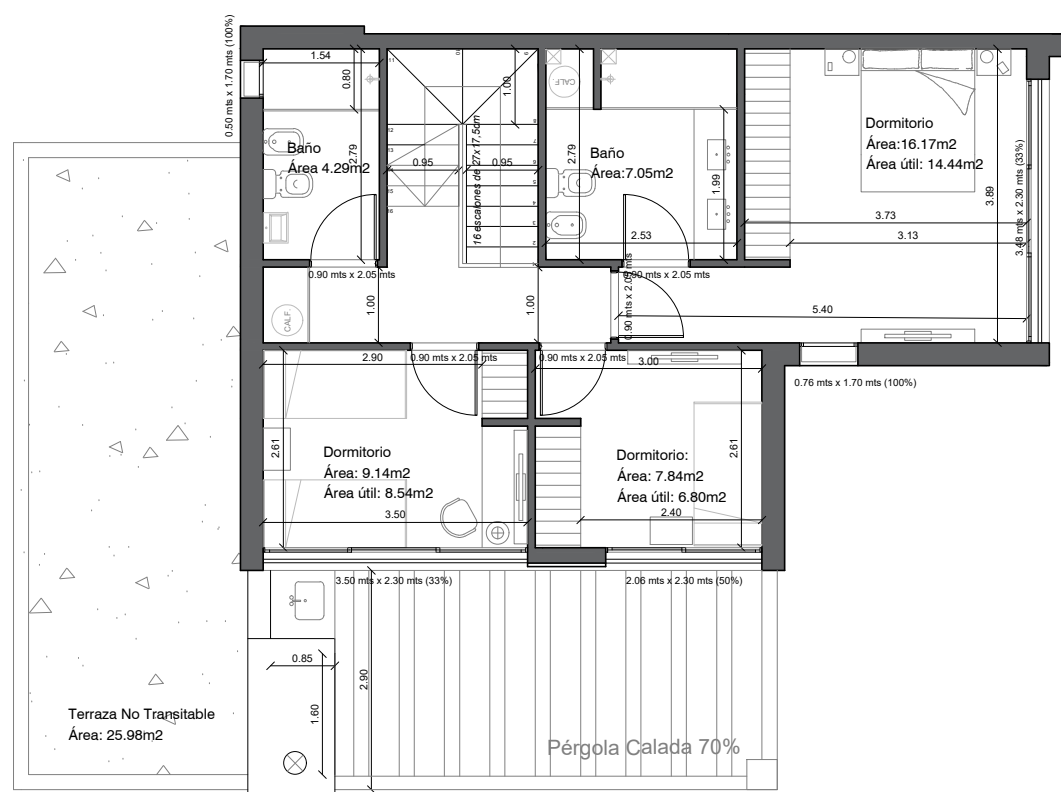
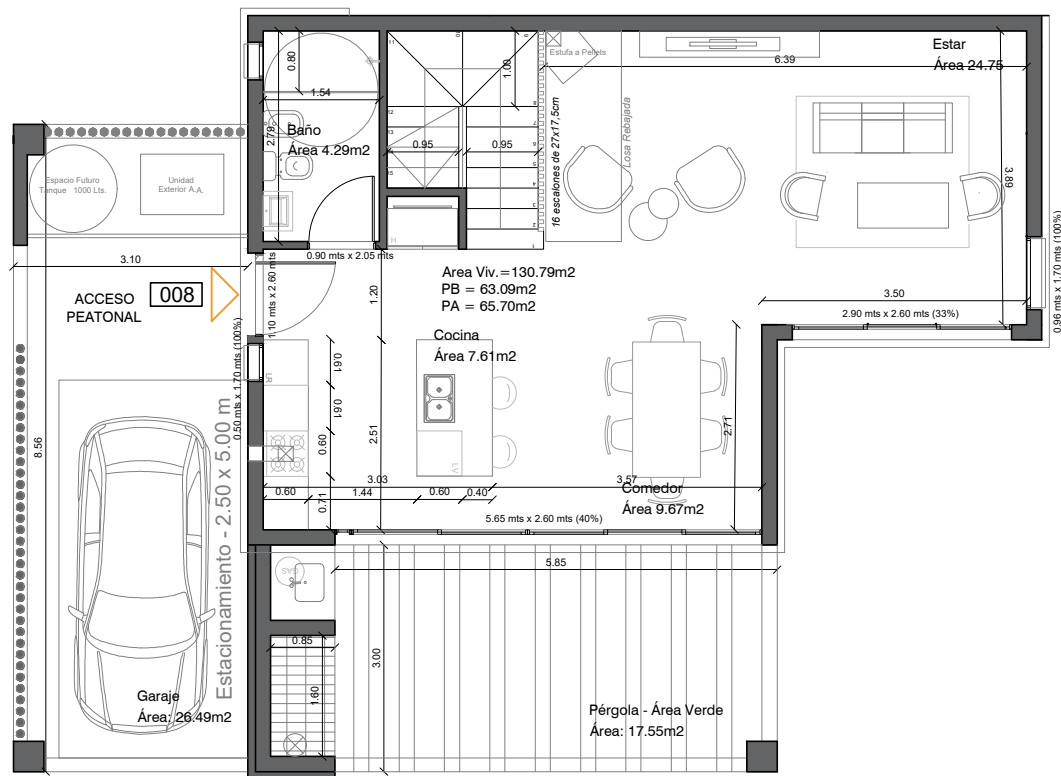

Apartamento 008 - Bloque A

130.79 m²

ÁREA TOTAL	304.55 m ²
ÁREA VIVIENDA	130.79 m ²
ÁREA DE USO EXCLUSIVO (sin viv.)	173.76 m ²

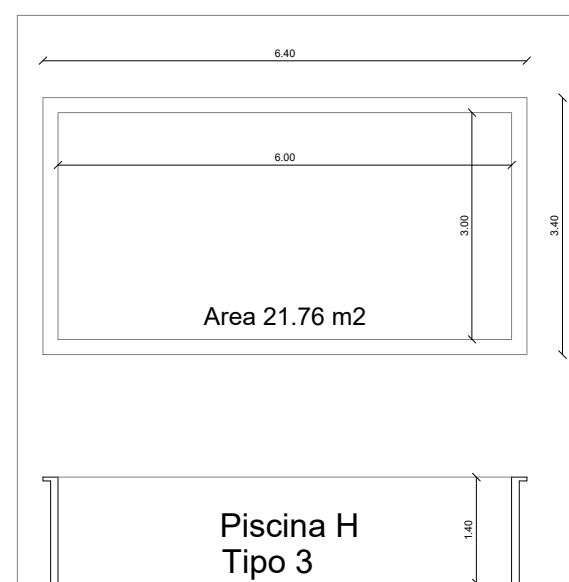

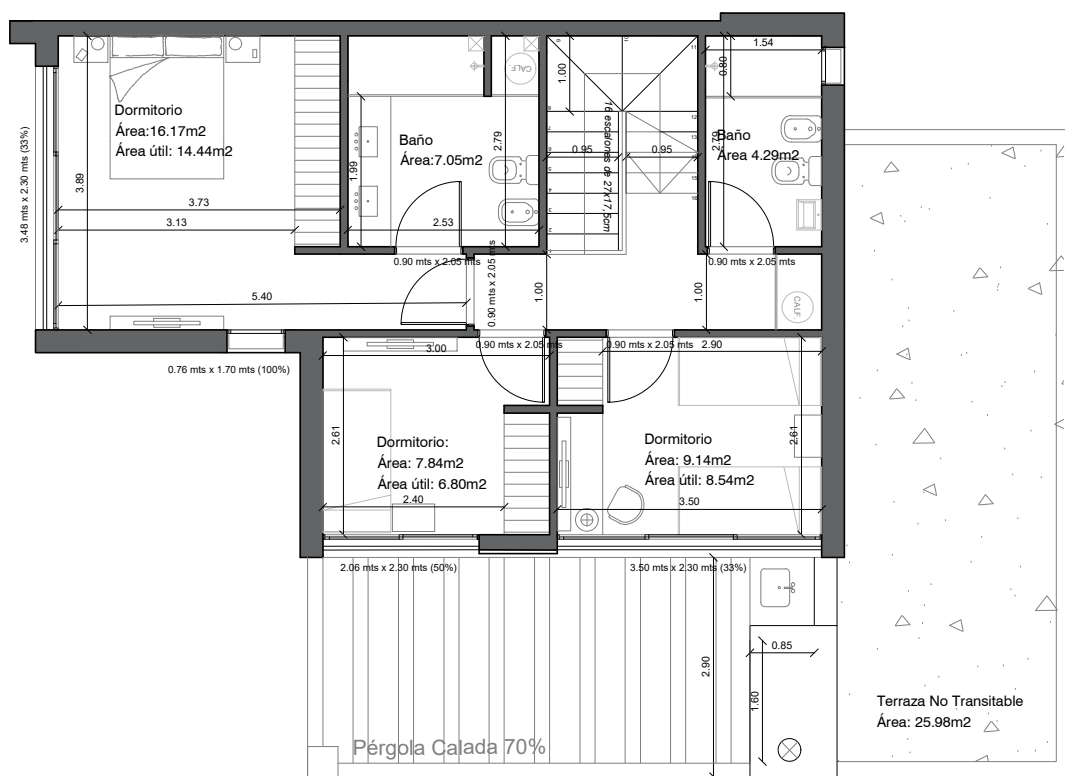
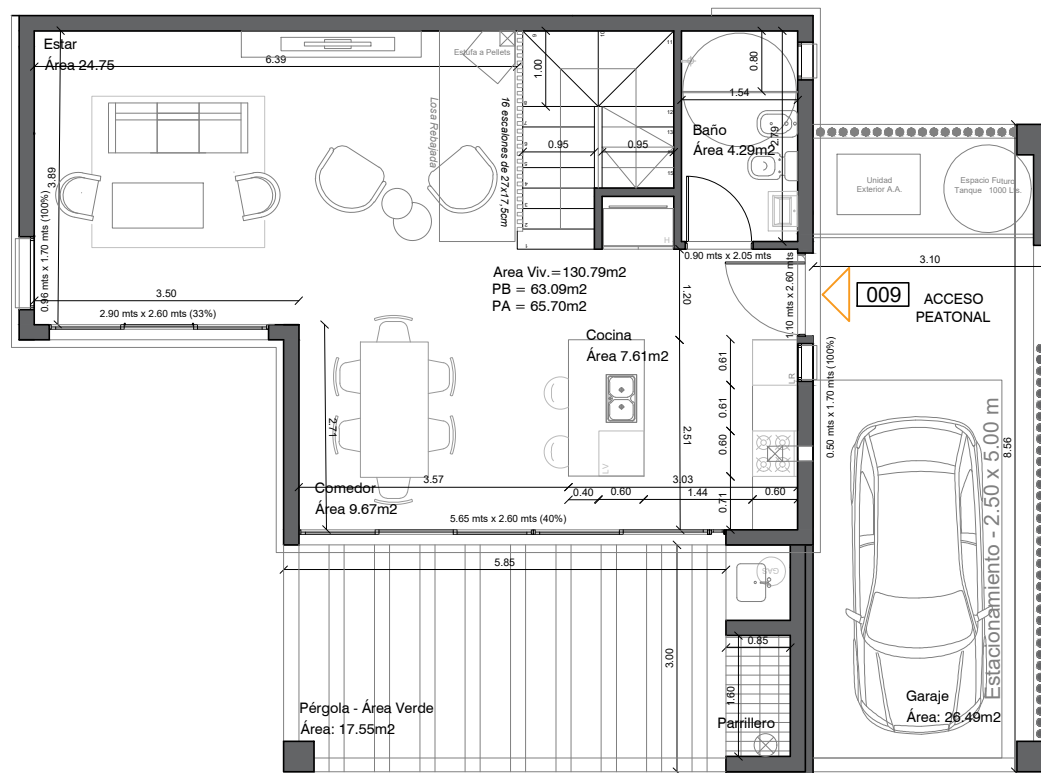

Apartamento 009 - Bloque B

130.79 m²

ÁREA TOTAL	281.01 m ²
ÁREA VIVIENDA	130.79 m ²
ÁREA DE USO EXCLUSIVO (sin viv.)	150.22 m ²

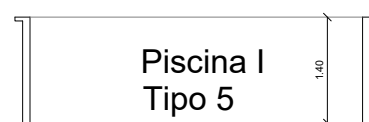
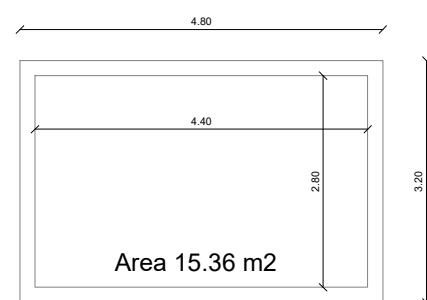

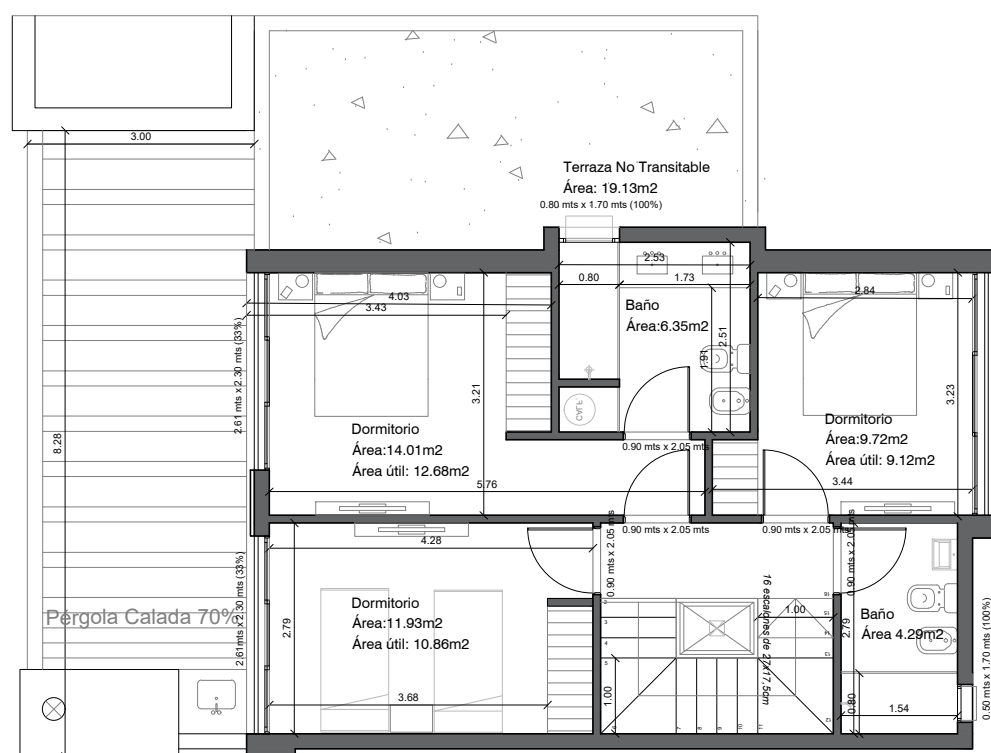
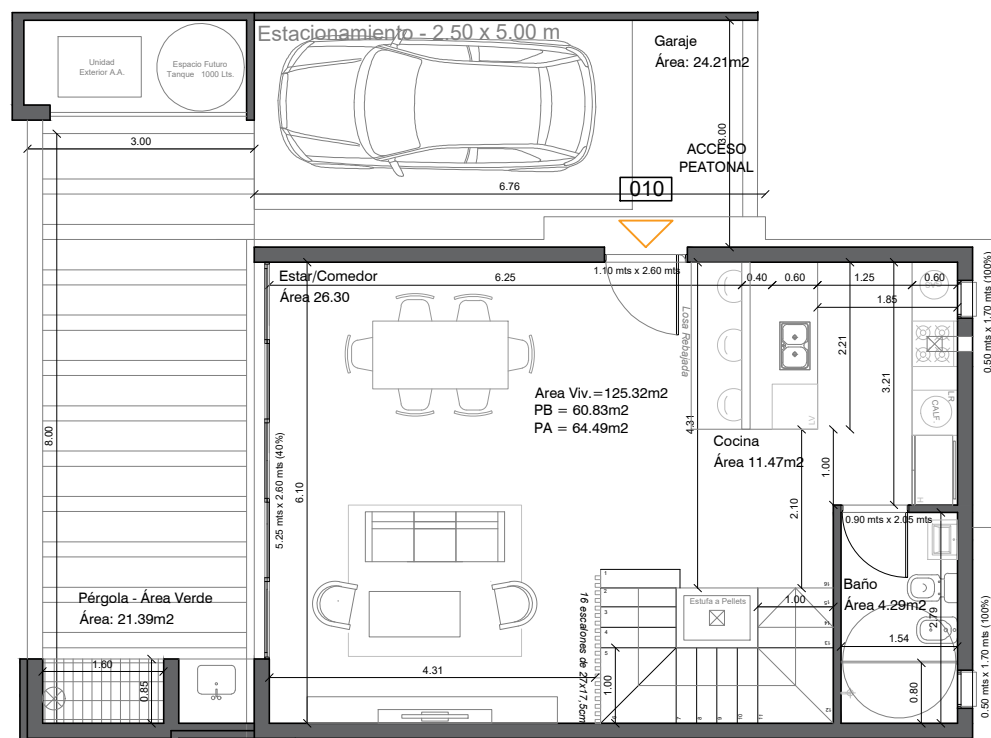

Apartamento 010 - Bloque B

125.32 m²

ÁREA TOTAL	269.64 m ²
ÁREA VIVIENDA	125.32 m ²
ÁREA DE USO EXCLUSIVO (sin viv.)	144.32 m ²

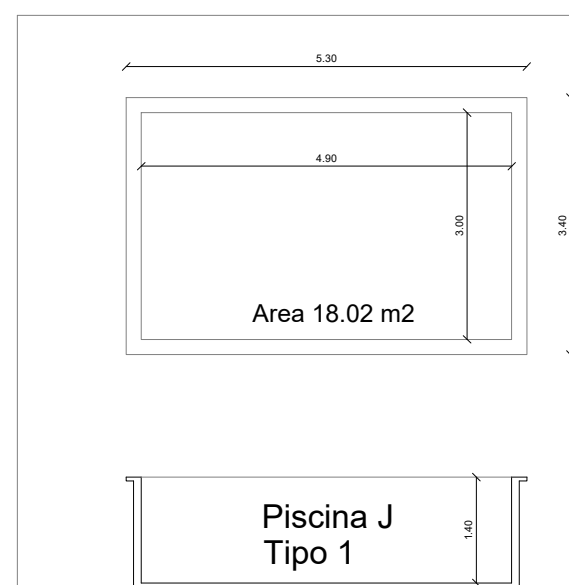

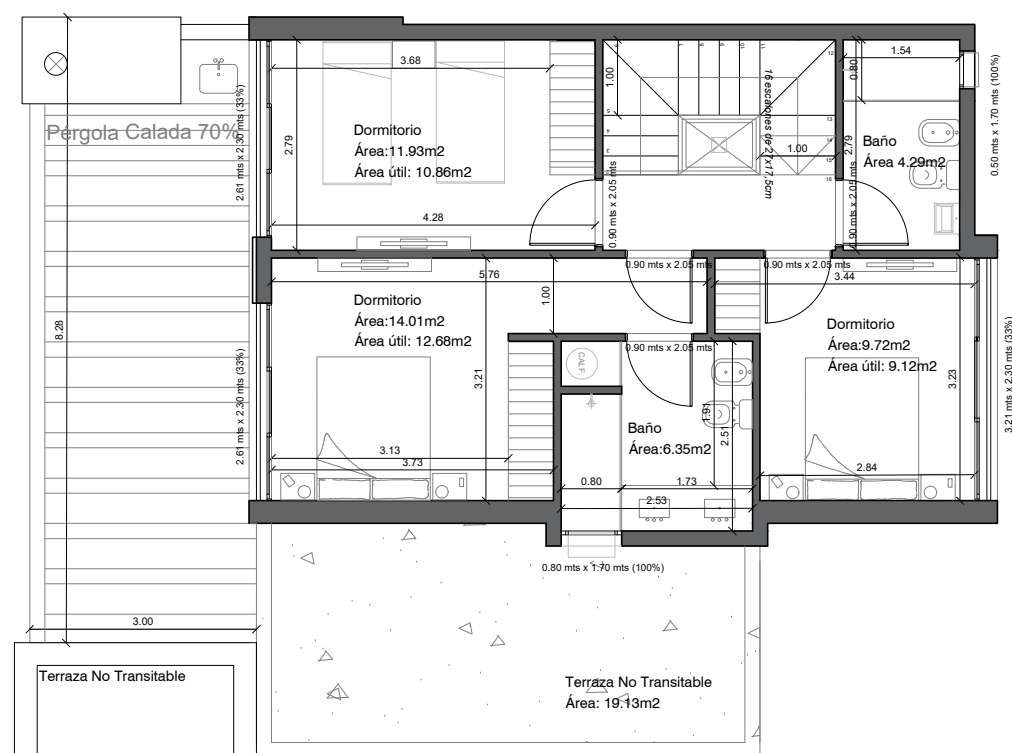
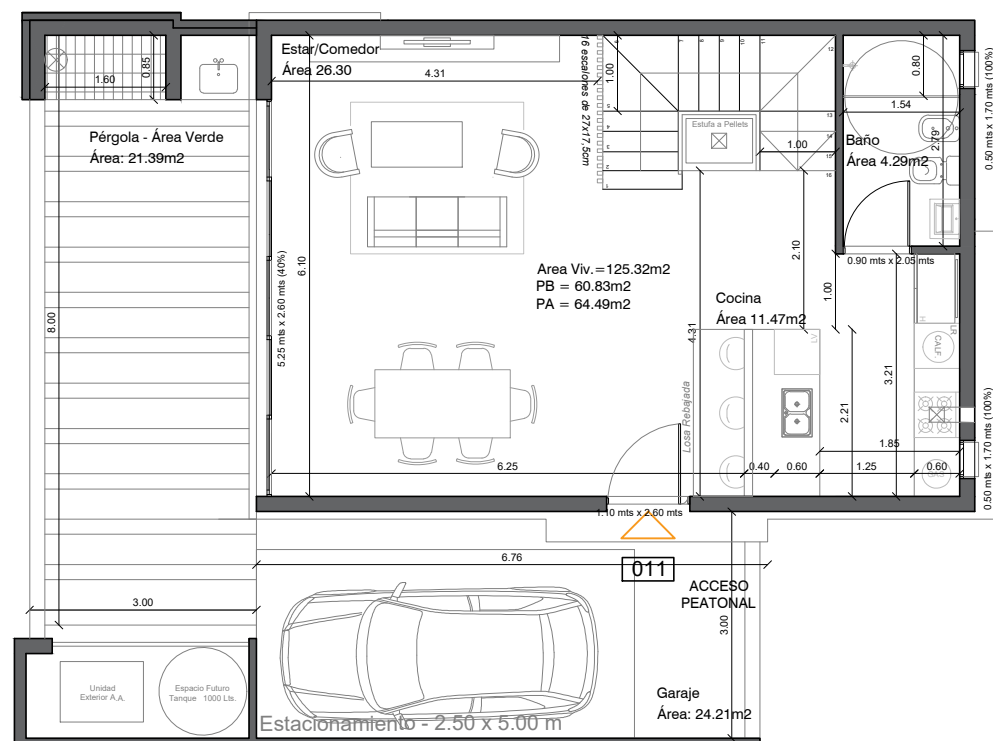

Apartamento 011 - Bloque B

125.32 m²

ÁREA TOTAL	260.29 m ²
ÁREA VIVIENDA	125.32 m ²
ÁREA DE USO EXCLUSIVO (sin viv.)	134.97 m ²

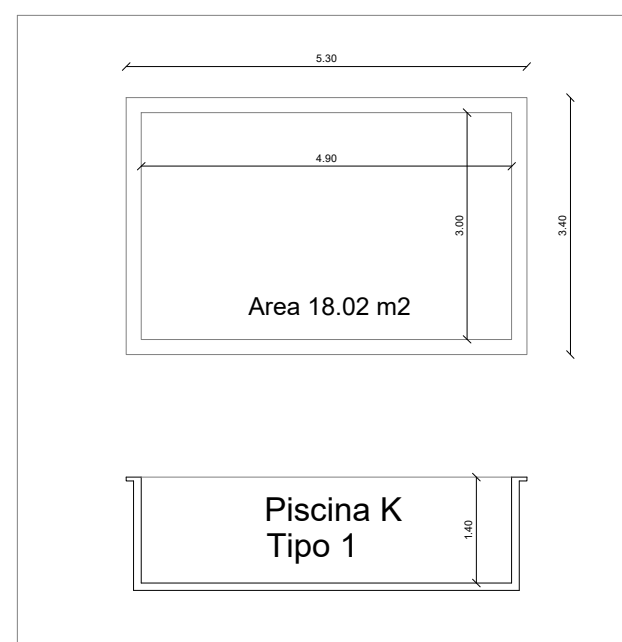

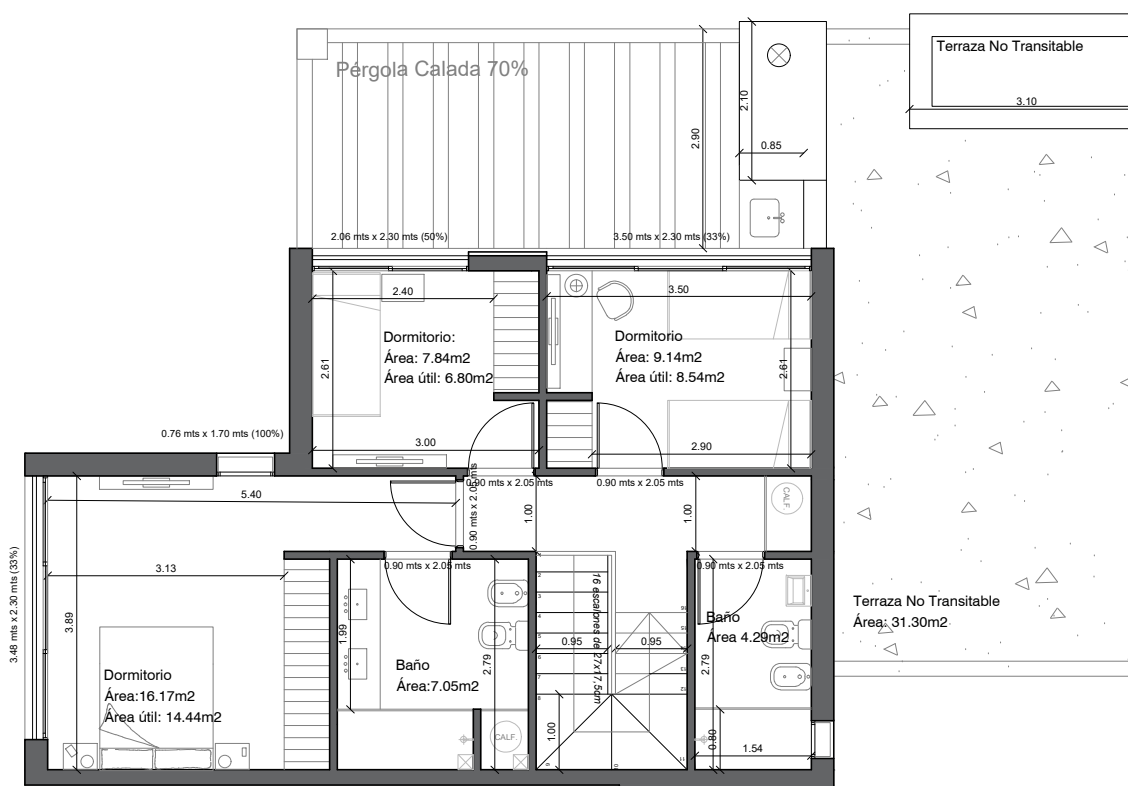
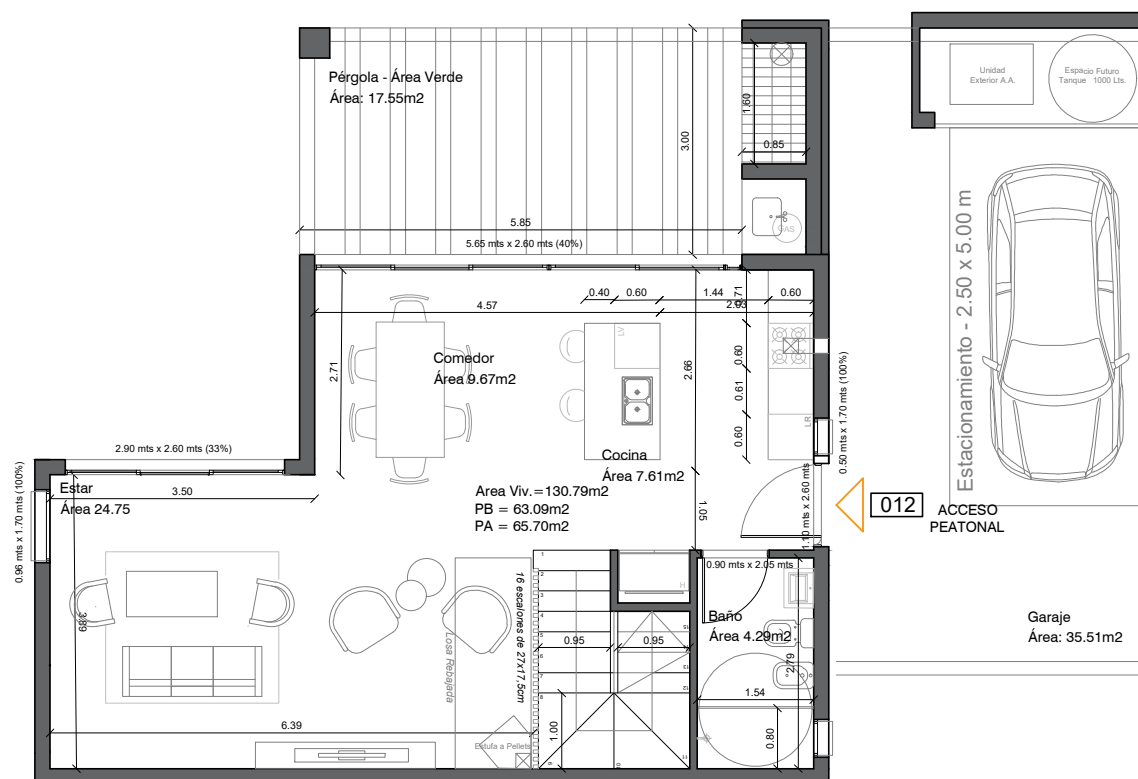

Apartamento 012 - Bloque B

130.79 m²

ÁREA TOTAL	373.07 m ²
ÁREA VIVIENDA	130.79 m ²
ÁREA DE USO EXCLUSIVO (sin viv.)	242.28 m ²

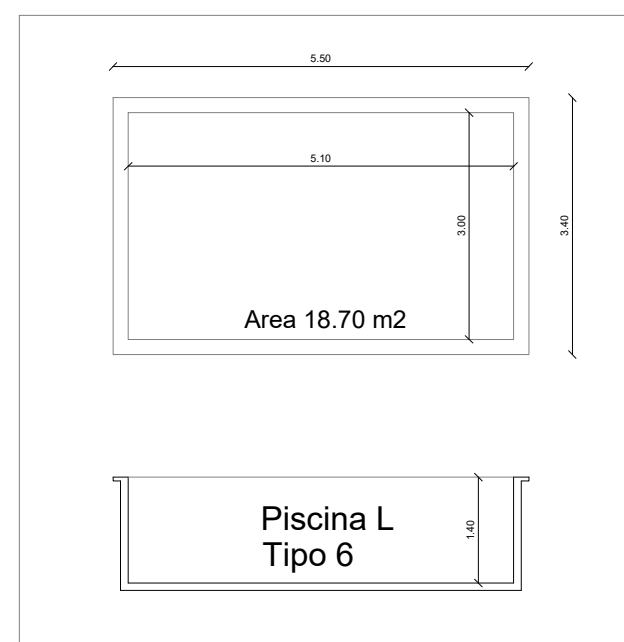

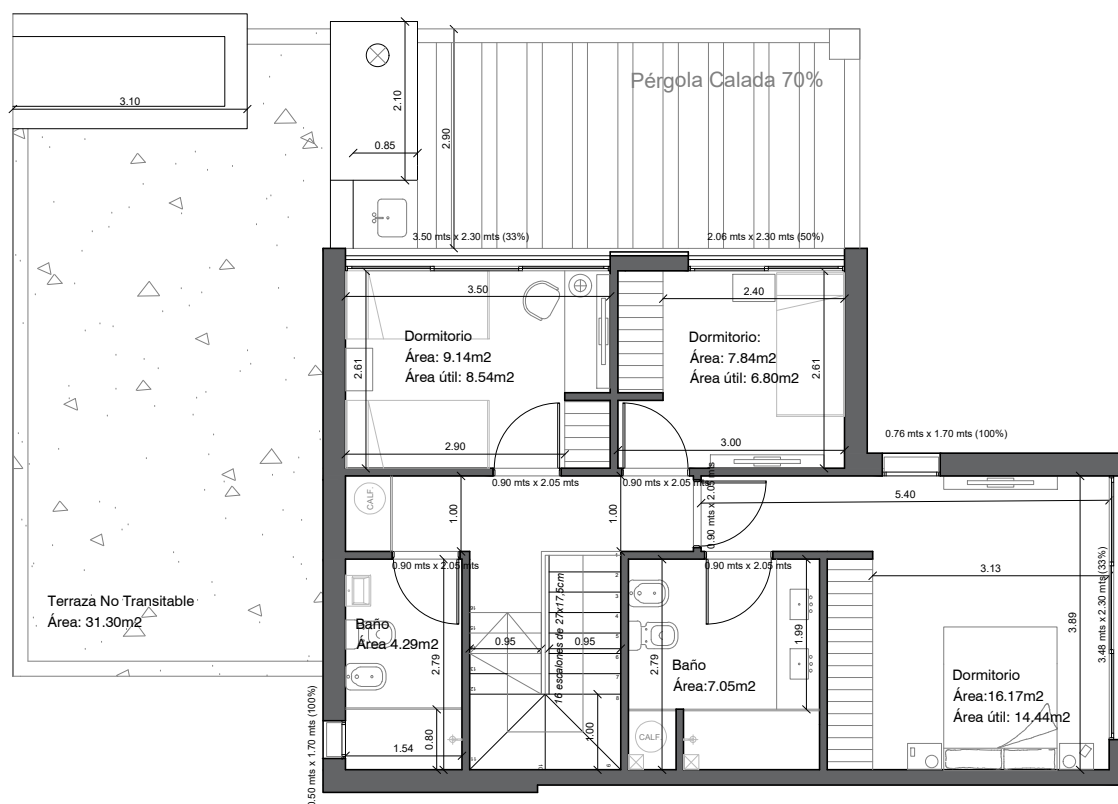

Apartamento 013 - Bloque B

130.79 m²

ÁREA TOTAL	373.07 m ²
ÁREA VIVIENDA	130.79 m ²
ÁREA DE USO EXCLUSIVO (sin viv.)	242.28 m ²

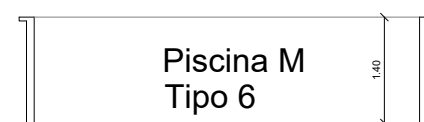
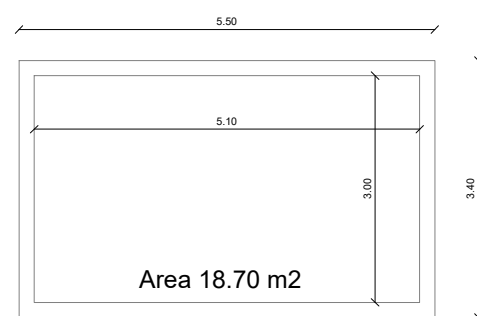

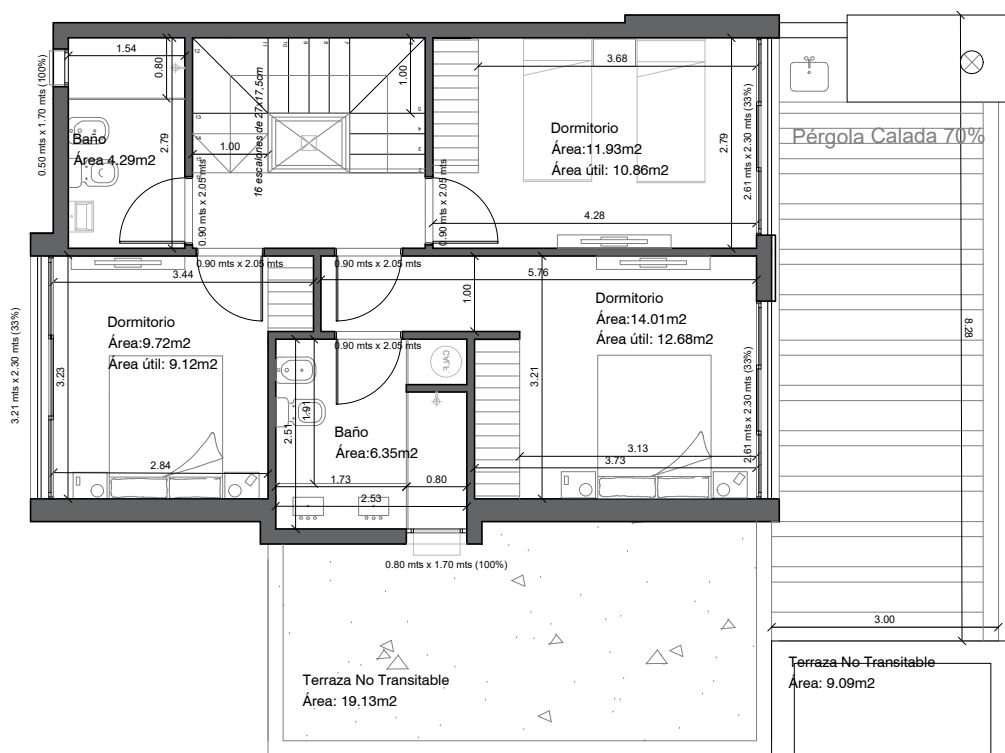
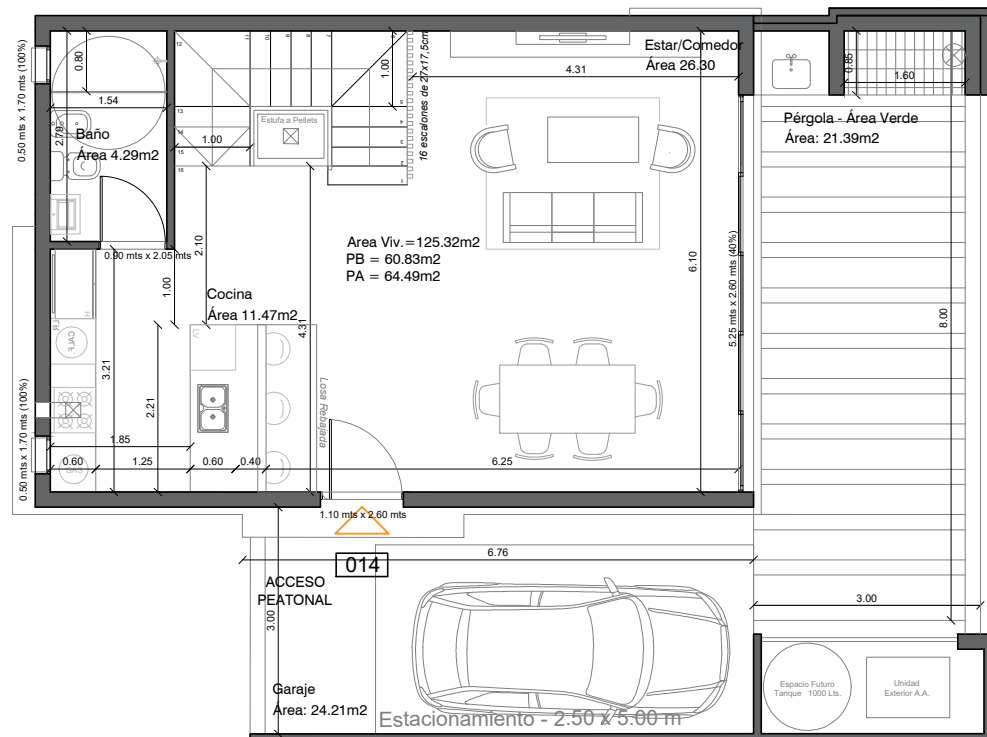

Apartamento 014 - Bloque B

125.32 m²

ÁREA TOTAL	262.12 m ²
ÁREA VIVIENDA	125.32 m ²
ÁREA DE USO EXCLUSIVO (sin viv.)	136.80 m ²

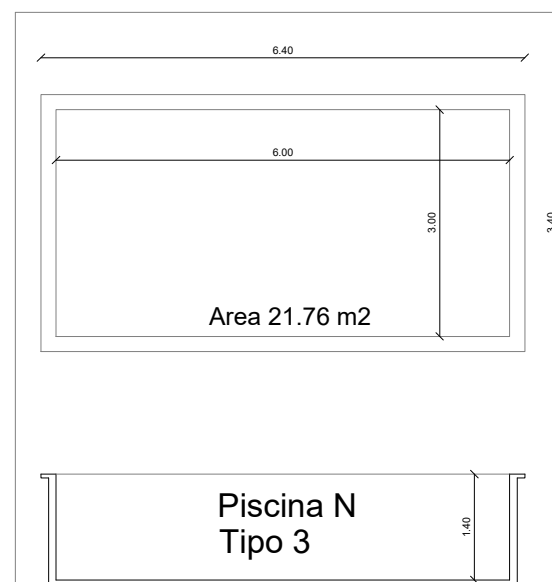

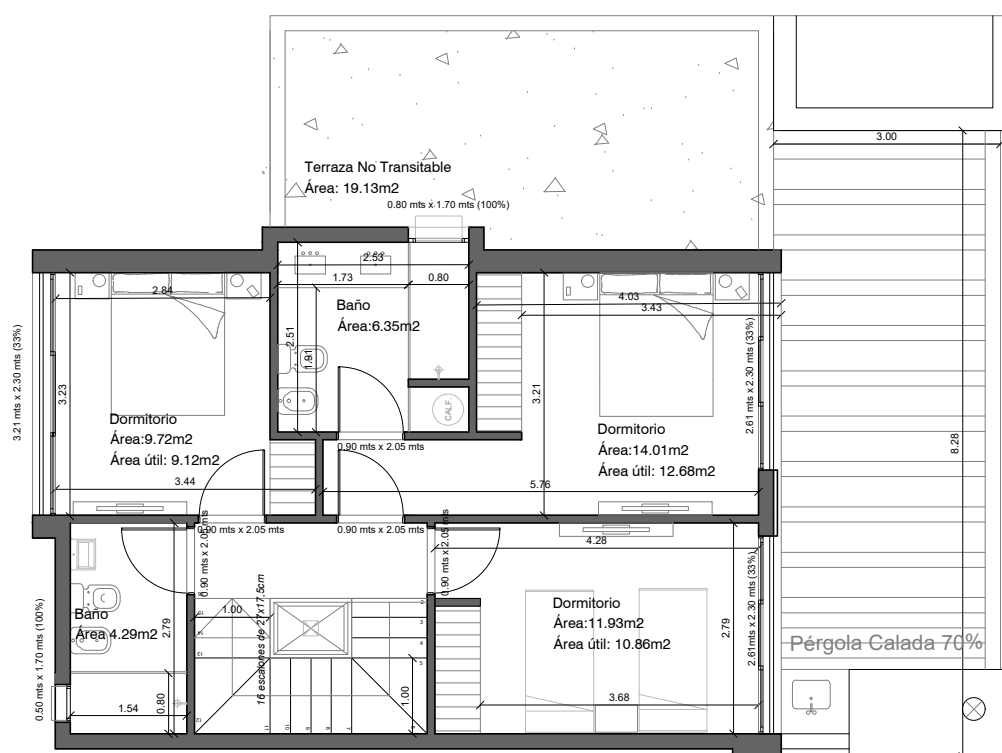
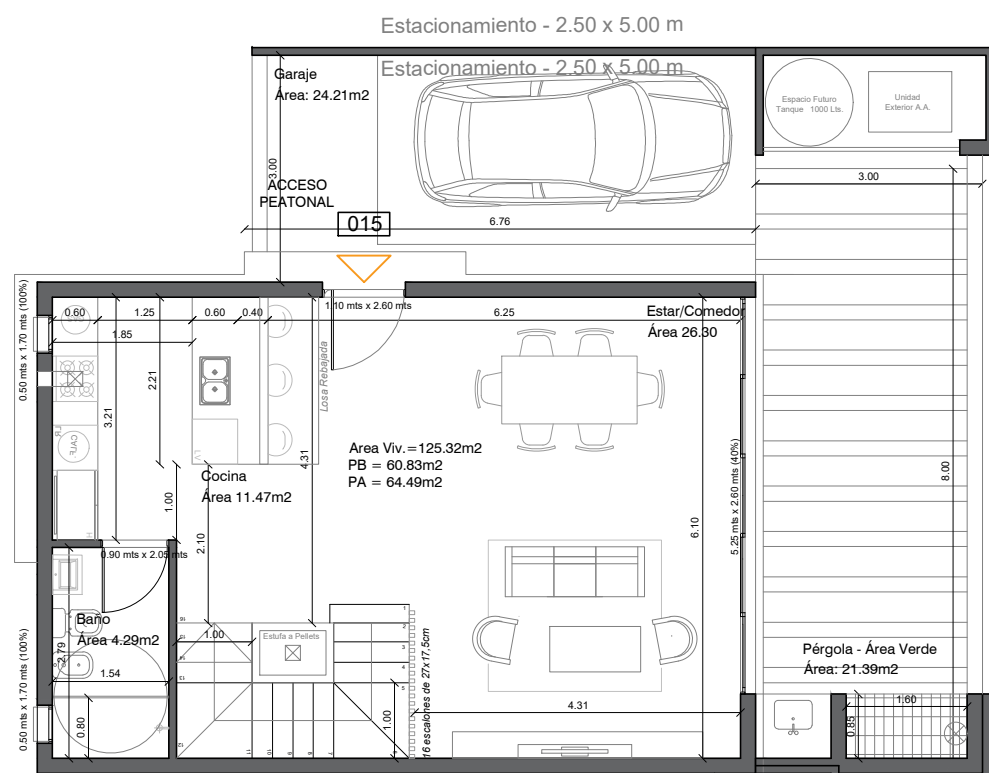

Apartamento 015 - Bloque B

125.32 m²

ÁREA TOTAL	283.73 m ²
ÁREA VIVIENDA	125.32 m ²
ÁREA DE USO EXCLUSIVO (sin viv.)	158.41 m ²

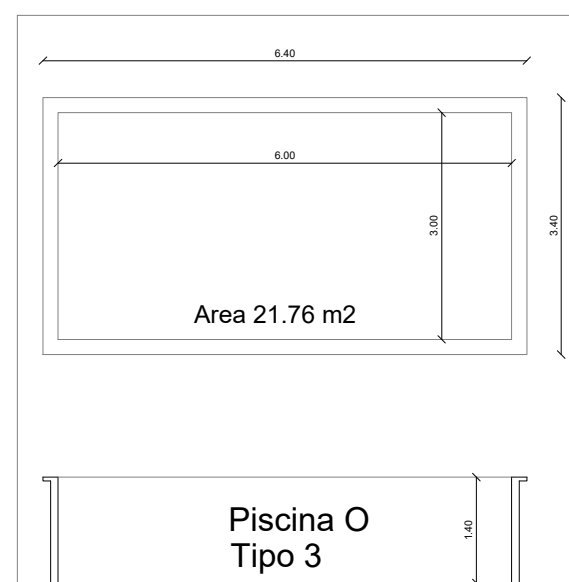

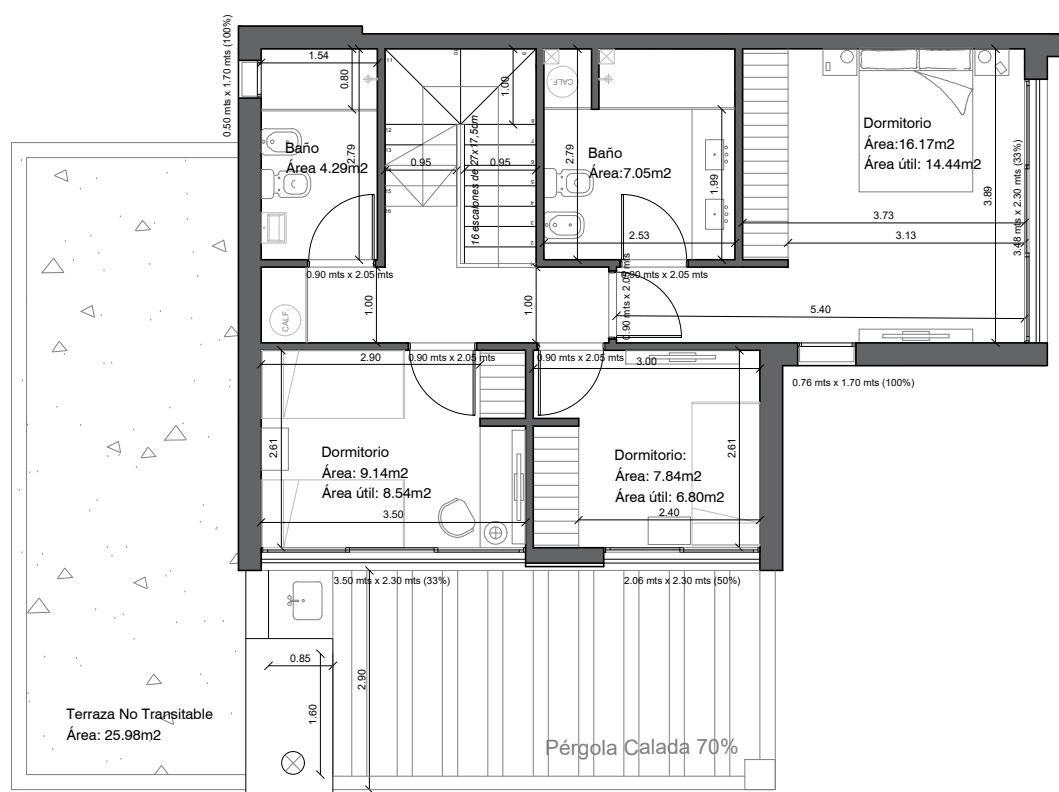
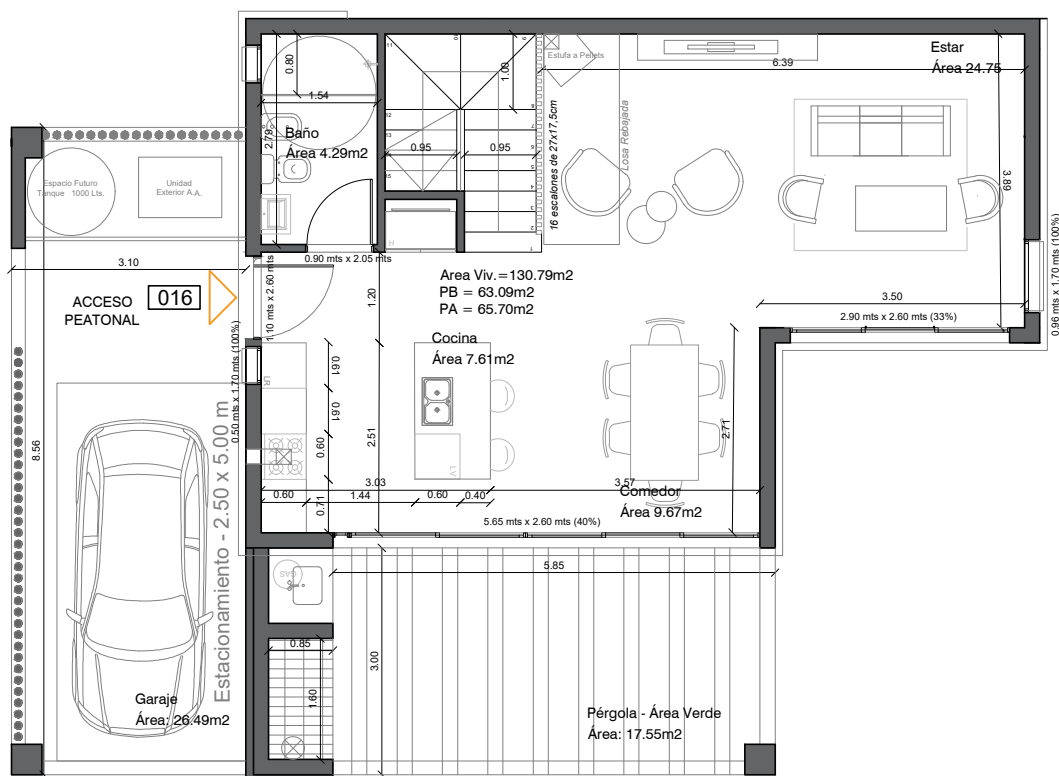

Apartamento 016 - Bloque B

130.79 m²

ÁREA TOTAL	257.03 m ²
ÁREA VIVIENDA	130.79 m ²
ÁREA DE USO EXCLUSIVO (sin viv.)	126.24 m ²

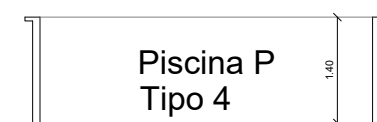
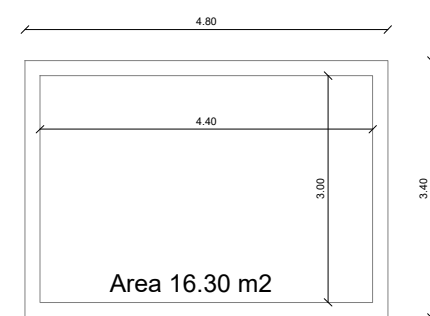

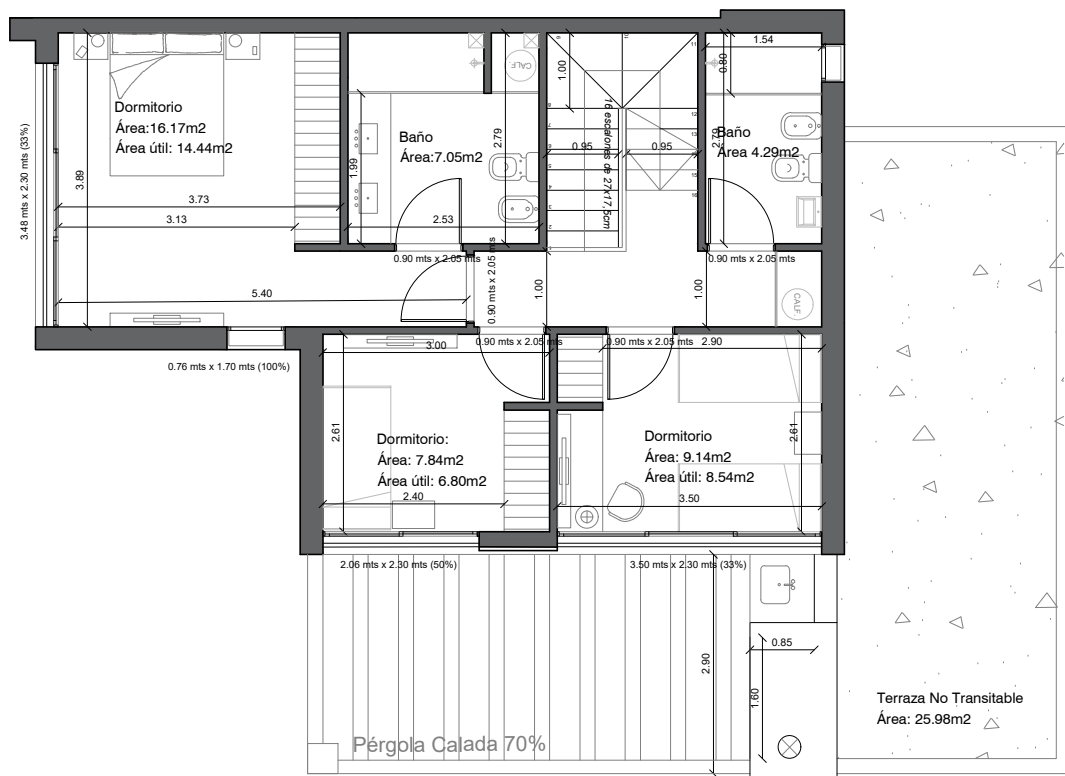
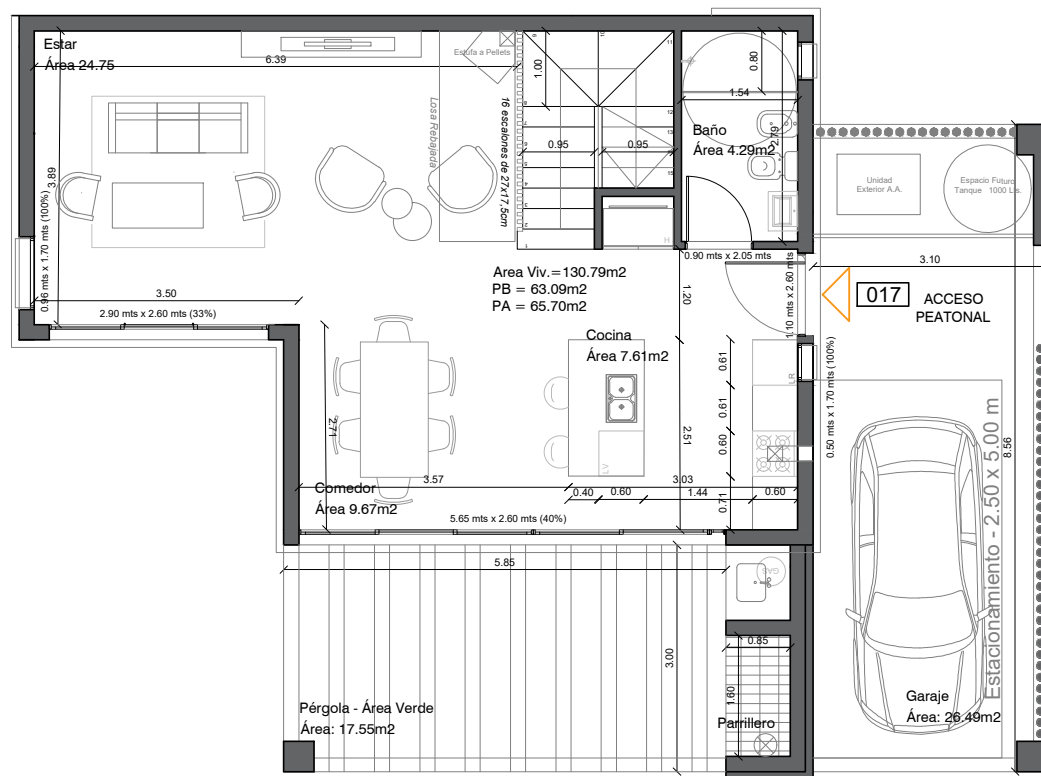

Apartamento 017 - Bloque C

130.79 m²

ÁREA TOTAL	259.17 m ²
ÁREA VIVIENDA	130.79 m ²
ÁREA DE USO EXCLUSIVO (sin viv.)	128.38 m ²

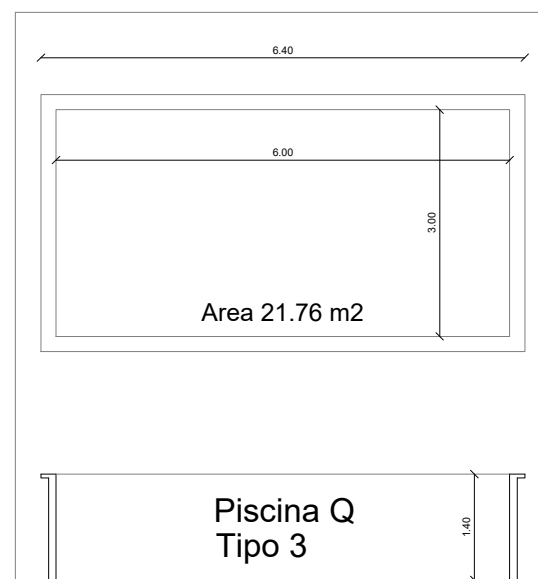

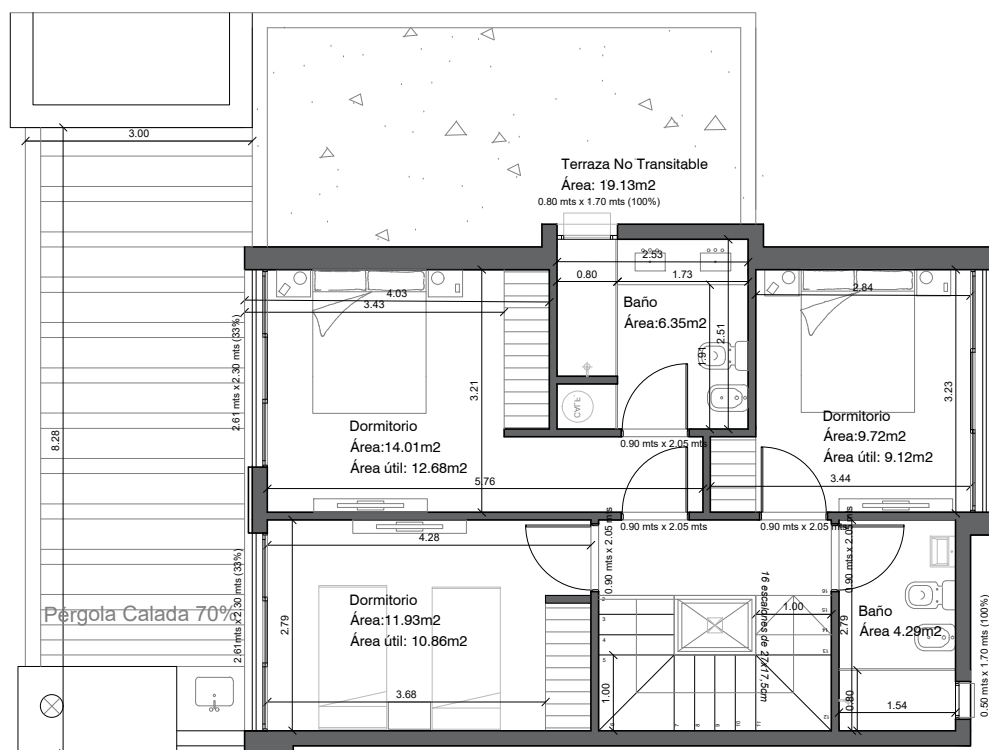
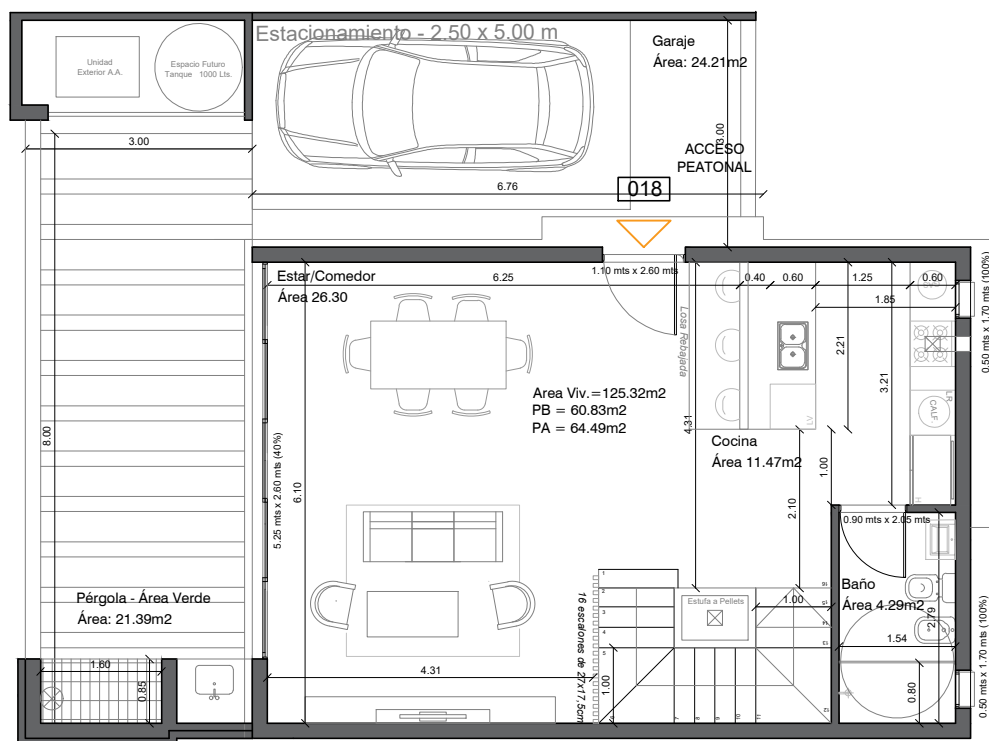

Apartamento 018 - Bloque C

125.32 m²

ÁREA TOTAL	237.03 m ²
ÁREA VIVIENDA	125.32 m ²
ÁREA DE USO EXCLUSIVO (sin viv.)	111.71 m ²

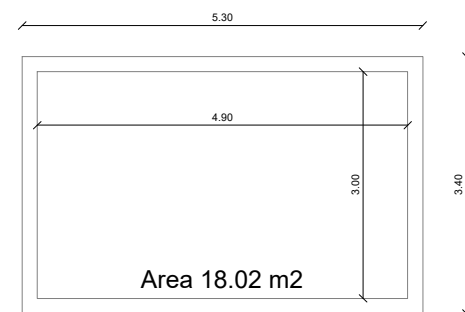

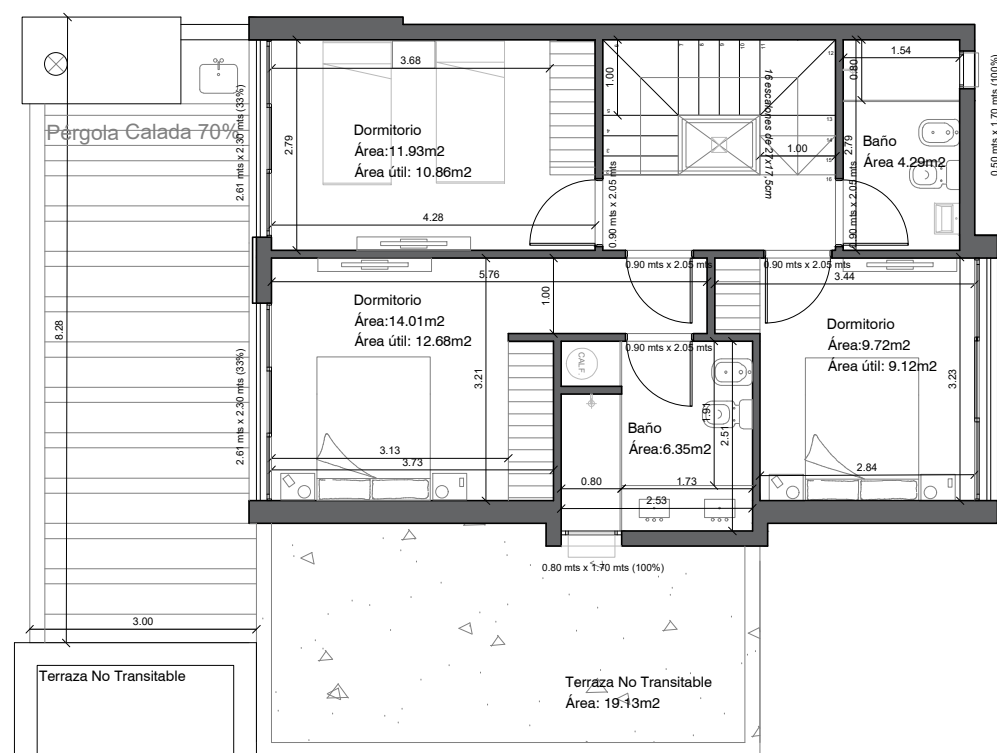
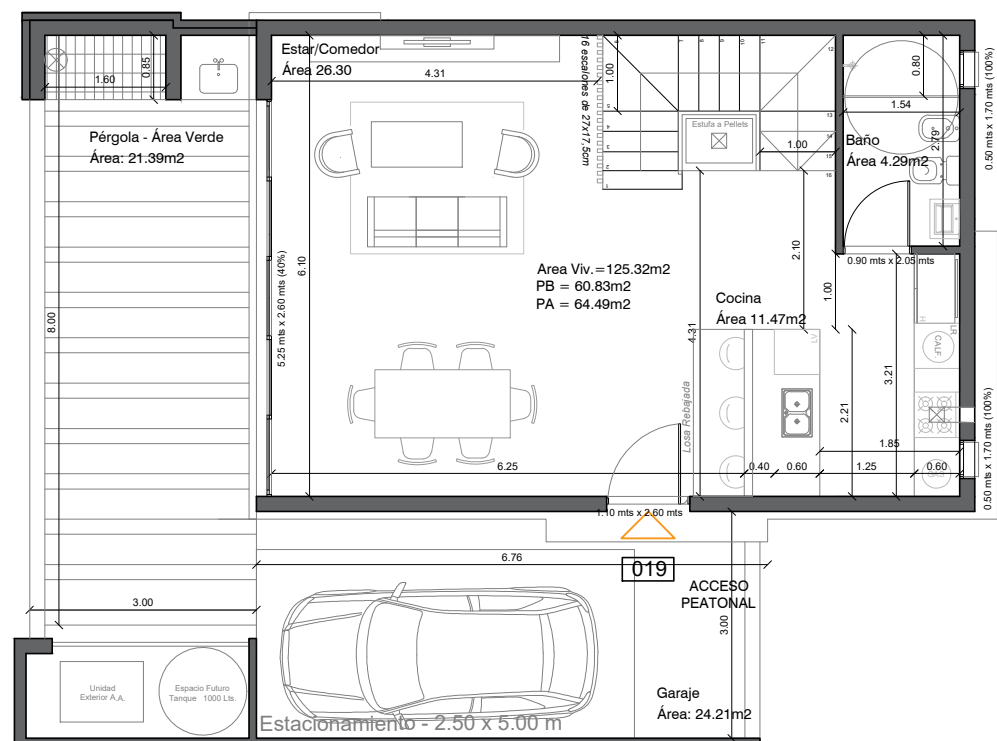

Apartamento 019 - Bloque C

125.32 m²

ÁREA TOTAL	320.59 m ²
ÁREA VIVIENDA	125.32 m ²
ÁREA DE USO EXCLUSIVO (sin viv.)	195.27 m ²

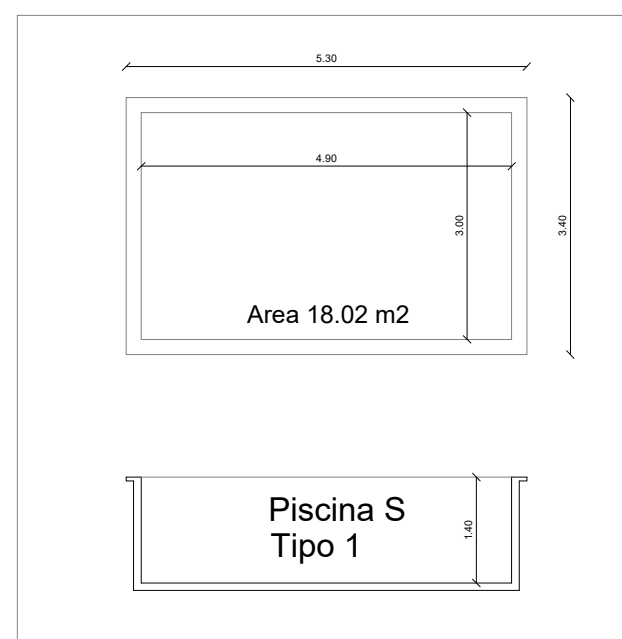

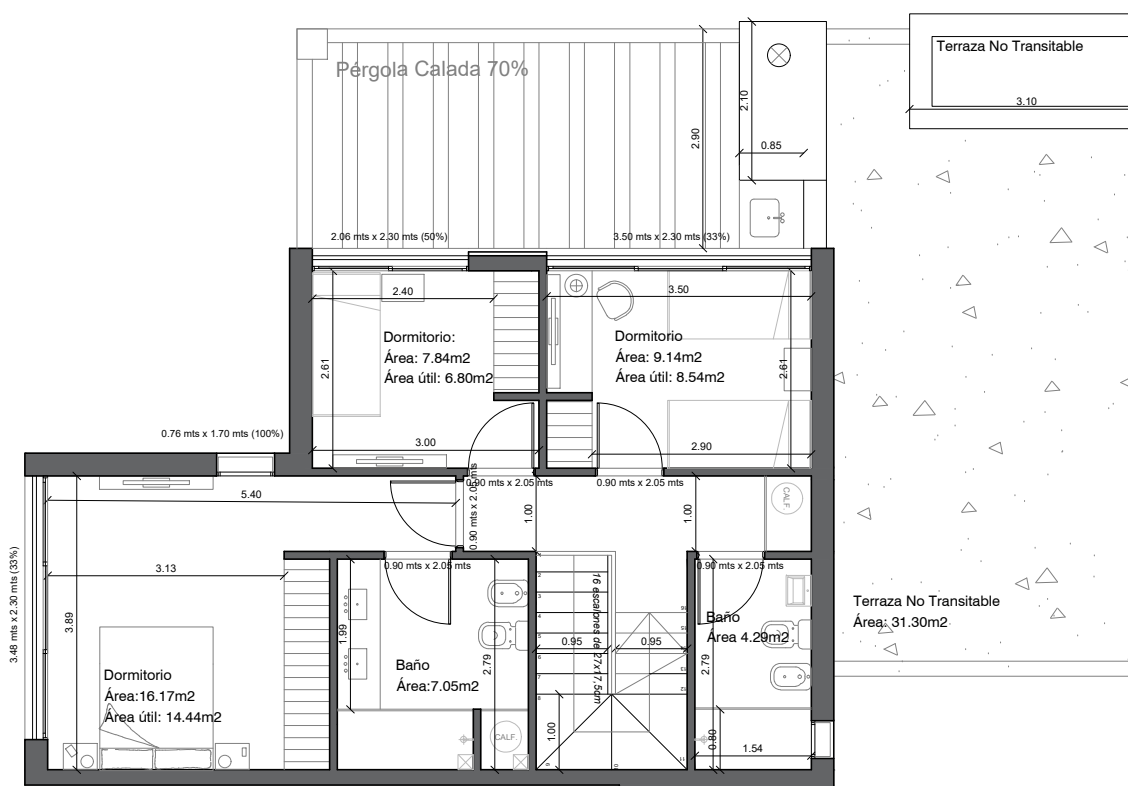
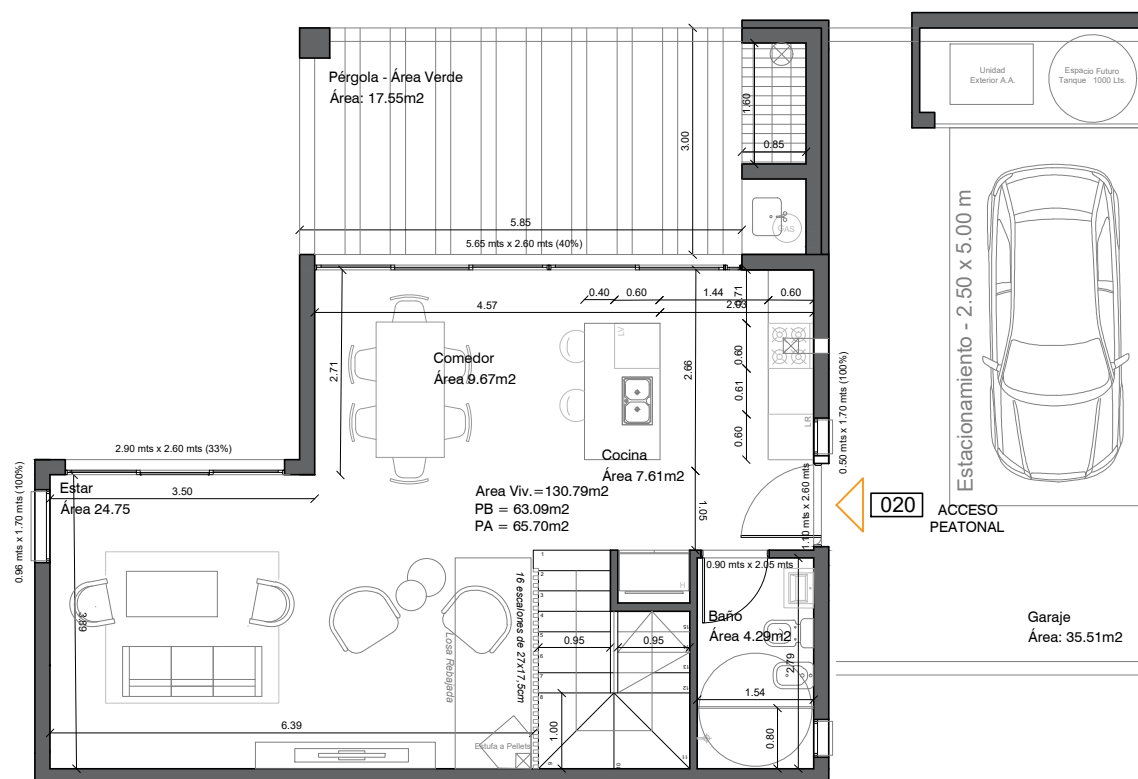

Apartamento 020 - Bloque C

130.79 m²

ÁREA TOTAL	366.91 m ²
ÁREA VIVIENDA	130.79 m ²
ÁREA DE USO EXCLUSIVO (sin viv.)	236.12 m ²

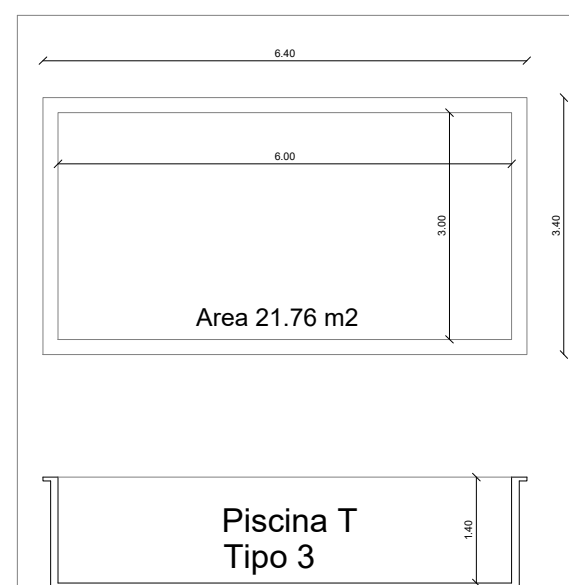

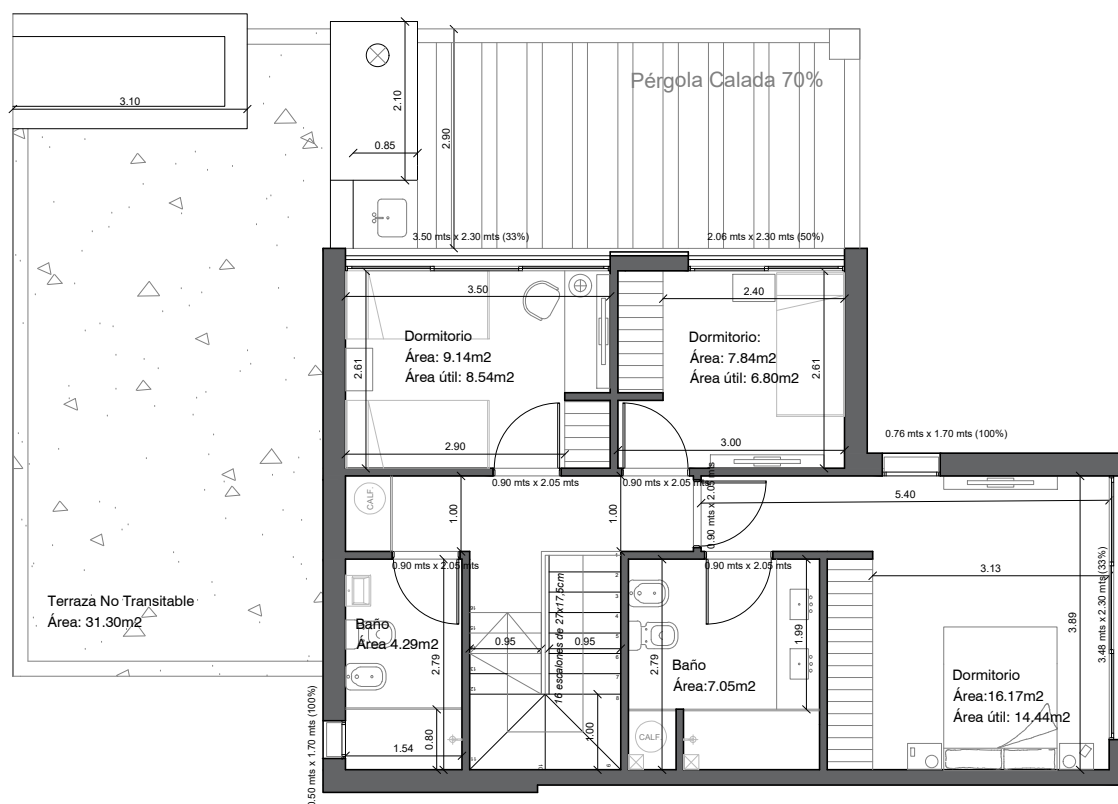

Apartamento 021 - Bloque C

130.79 m²

ÁREA TOTAL	327.48 m ²
ÁREA VIVIENDA	130.79 m ²
ÁREA DE USO EXCLUSIVO (sin viv.)	196.69 m ²

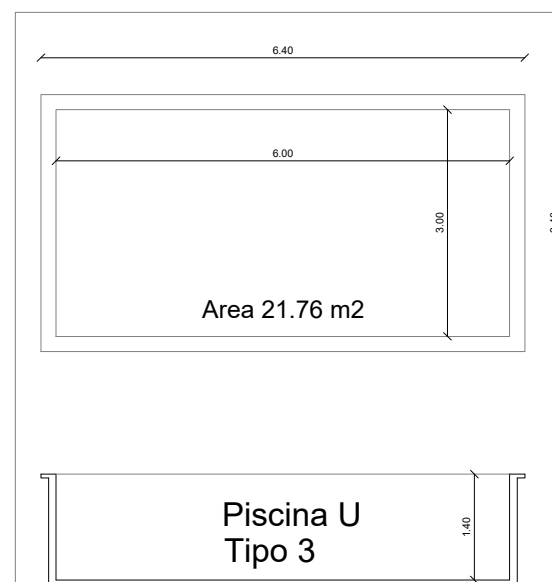

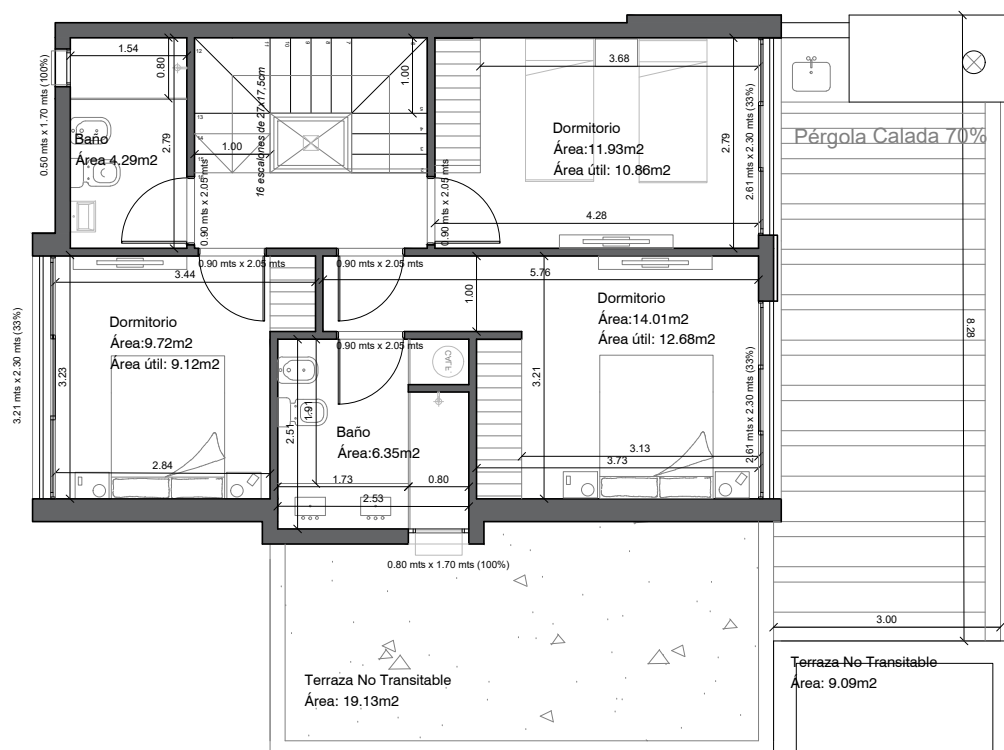
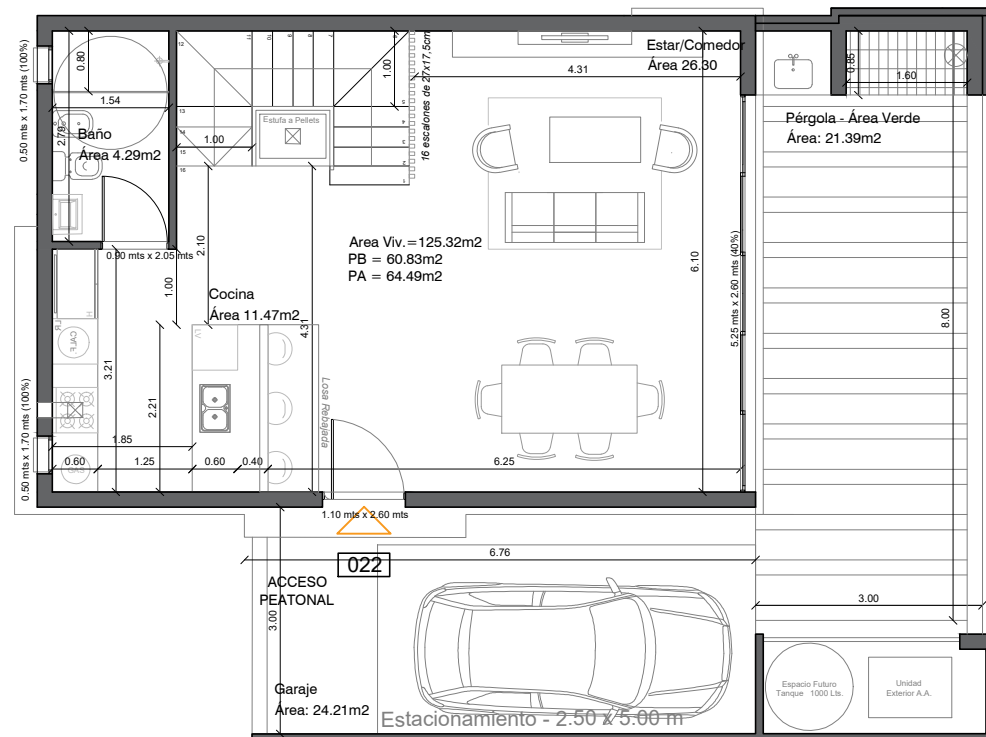

Apartamento 022 - Bloque C

125.32 m²

ÁREA TOTAL	283.67 m ²
ÁREA VIVIENDA	125.32 m ²
ÁREA DE USO EXCLUSIVO (sin viv.)	158.35 m ²

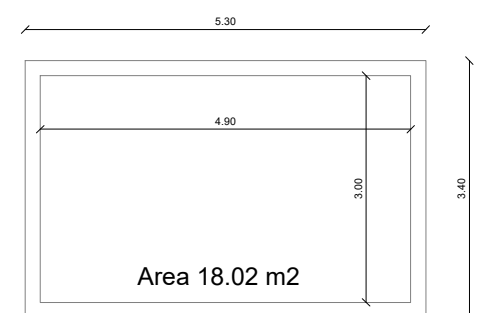

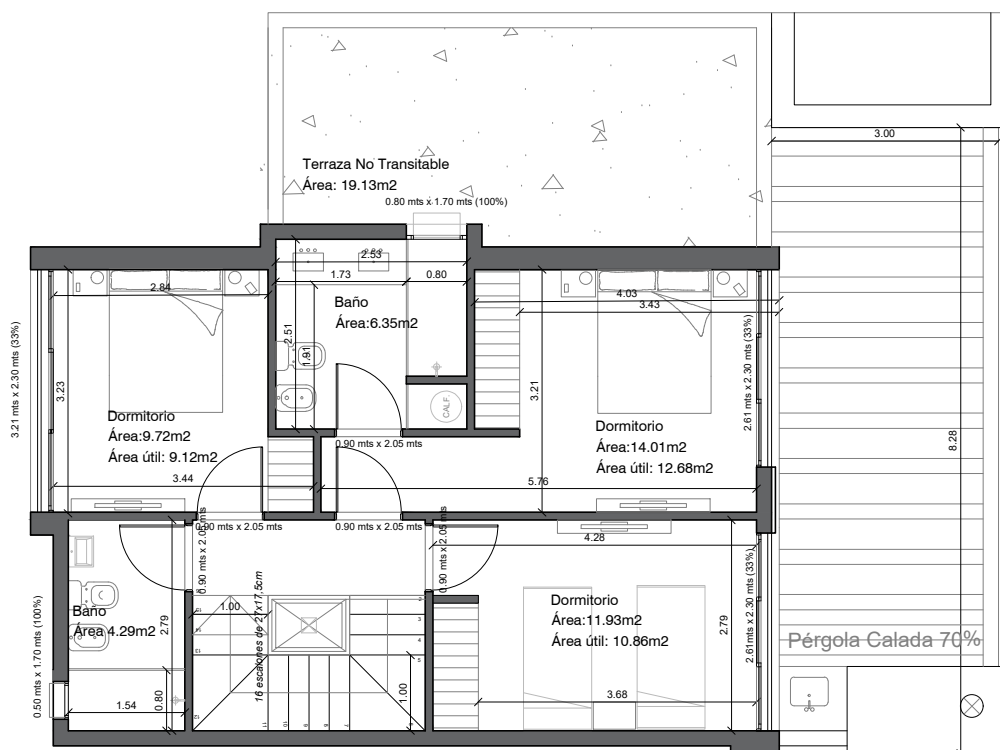
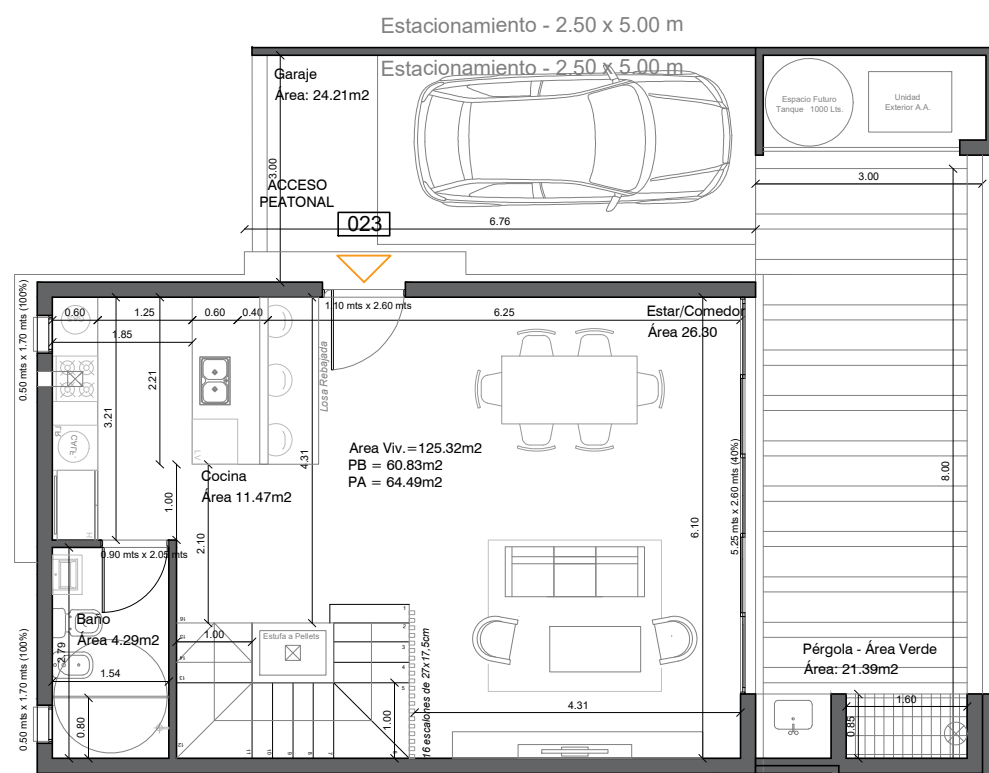

Apartamento 023 - Bloque C

125.32 m²

ÁREA TOTAL	388.13 m ²
ÁREA VIVIENDA	125.32 m ²
ÁREA DE USO EXCLUSIVO (sin viv.)	262.81 m ²

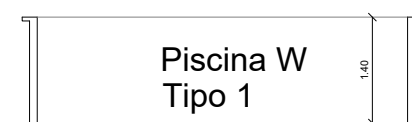
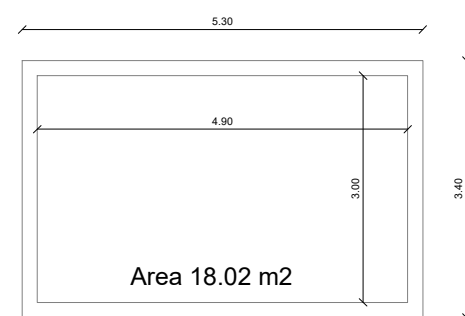

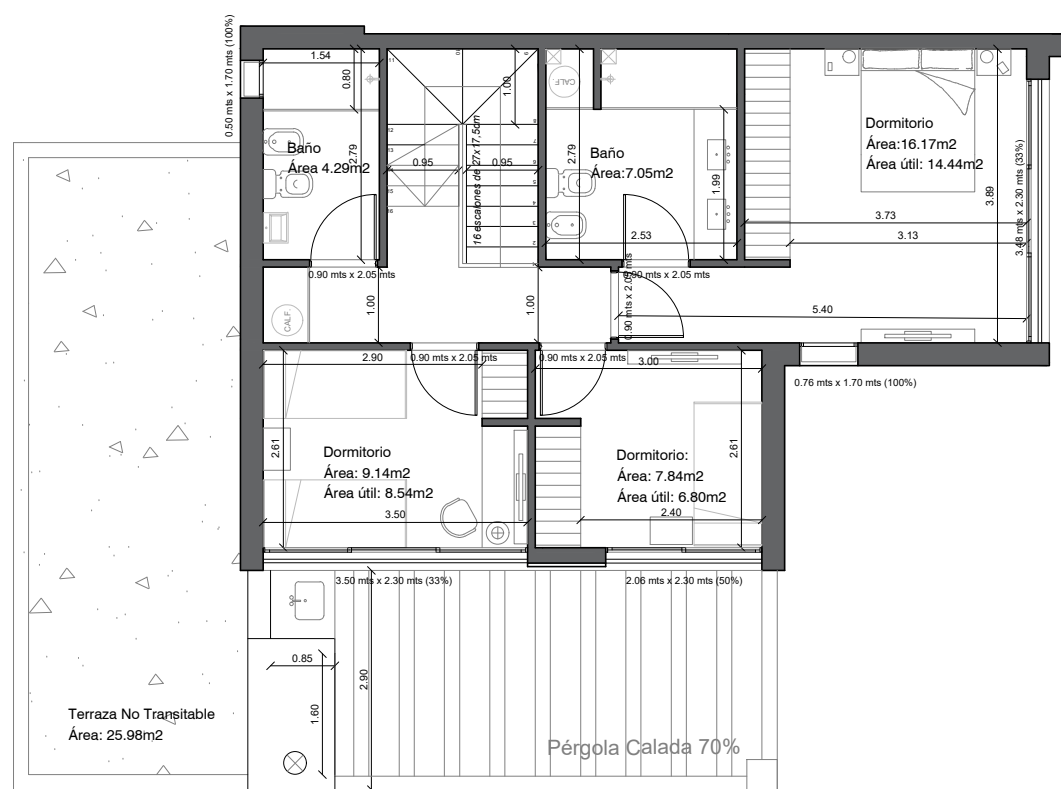
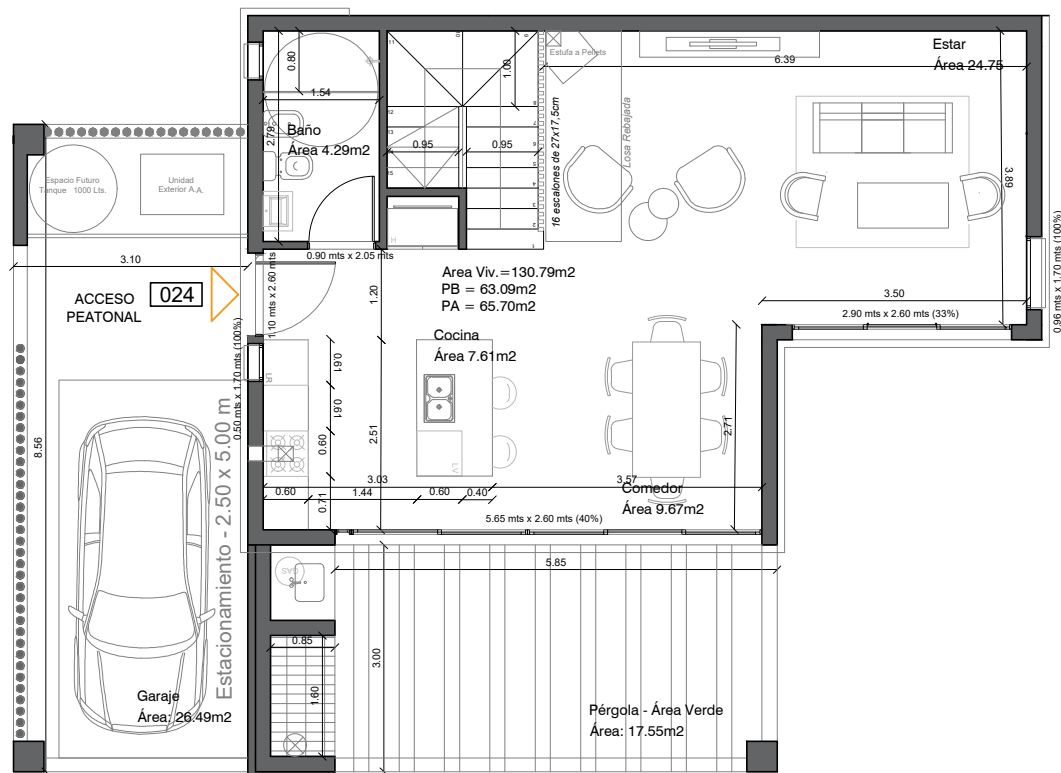

Apartamento 024 - Bloque C

130.79 m²

ÁREA TOTAL	536.65 m ²
ÁREA VIVIENDA	130.79 m ²
ÁREA DE USO EXCLUSIVO (sin viv.)	405.86 m ²

